



**NAVAL
POSTGRADUATE
SCHOOL**

MONTEREY, CALIFORNIA

THESIS

**APPLICABILITY OF DODAF TO THE CONVERSION OF
A CRANE SHIP TO HOST A BALLISTIC MISSILE
DEFENSE TEST RADAR AND TELEMETRY SYSTEM**

by

Michael E. Lash

June 2010

Thesis Advisor:

C. N. Calvano

Second Reader:

C. Whitcomb

Approved for public release; distribution is unlimited

THIS PAGE INTENTIONALLY LEFT BLANK

REPORT DOCUMENTATION PAGE			<i>Form Approved OMB No. 0704-0188</i>
Public reporting burden for this collection of information is estimated to average 1 hour per response, including the time for reviewing instruction, searching existing data sources, gathering and maintaining the data needed, and completing and reviewing the collection of information. Send comments regarding this burden estimate or any other aspect of this collection of information, including suggestions for reducing this burden, to Washington headquarters Services, Directorate for Information Operations and Reports, 1215 Jefferson Davis Highway, Suite 1204, Arlington, VA 22202-4302, and to the Office of Management and Budget, Paperwork Reduction Project (0704-0188) Washington DC 20503.			
1. AGENCY USE ONLY (Leave blank)	2. REPORT DATE June 2010	3. REPORT TYPE AND DATES COVERED Master's Thesis	
4. TITLE AND SUBTITLE Applicability of DoDAF to the Conversion of a Crane Ship to Host a Ballistic Missile Defense Test Radar and Telemetry System		5. FUNDING NUMBERS	
6. AUTHOR(S) Michael E. Lash		8. PERFORMING ORGANIZATION REPORT NUMBER	
7. PERFORMING ORGANIZATION NAME(S) AND ADDRESS(ES) Naval Postgraduate School Monterey, CA 93943-5000		10. SPONSORING/MONITORING AGENCY REPORT NUMBER	
9. SPONSORING /MONITORING AGENCY NAME(S) AND ADDRESS(ES) Missile Defense Agency BLD 5222 Redstone Arsenal, Al 35898		11. SUPPLEMENTARY NOTES The views expressed in this thesis are those of the author and do not reflect the official policy or position of the Department of Defense or the U.S. Government.	
12a. DISTRIBUTION / AVAILABILITY STATEMENT Approved for public release; distribution is unlimited		12b. DISTRIBUTION CODE	
13. ABSTRACT (maximum 200 words) Currently, all Missile Defense Agency (MDA) instrumentation radars are land-based at Reagan Test Site (RTS) in the Marshall Islands and the Pacific Missile Range Facility (PMRF) on the Hawaiian island of Kauai. The dependency on land-based radars produces significant gaps in radar coverage of planned ballistic missile defense system (BMDS) tests. The S.S. Beaver State is a former cargo ship that was converted to a crane ship. The purpose of a crane ship is to unload/load other ships at ports with inadequate facilities. When the Beaver State was converted to a crane ship, three large cranes were installed. The size of the ship and generators make the Beaver State suitable to host the first X-Band Test Radar (XTR-1) and the second Transportable Telemetry System (TTS-2). There are five major efforts in the conversion process: 1) Ship reactivation; 2) Modification of the ship to host the primary sensors, the adjunct systems, and the respective operators; 3) Installation and integration of the primary sensors and adjunct systems; 4) Development, installation, and certification of the communications system; and 5) Coast Guard certification. This thesis will review the history of the modification design and communications system development aspects of this conversion process, review the Department of Defense Architectural Framework (DoDAF), assess the applicability of DoDAF to the Beaver State conversion process, and suggest opportunities for improvement of similar MDA test asset development programs.			
14. SUBJECT TERMS Department of Defense Architectural Framework, DoDAF, Systems View, Operational View, Missile Defense		15. NUMBER OF PAGES 99	
		16. PRICE CODE	
17. SECURITY CLASSIFICATION OF REPORT Unclassified	18. SECURITY CLASSIFICATION OF THIS PAGE Unclassified	19. SECURITY CLASSIFICATION OF ABSTRACT Unclassified	20. LIMITATION OF ABSTRACT UU

THIS PAGE INTENTIONALLY LEFT BLANK

Approved for public release; distribution is unlimited

**APPLICABILITY OF DODAF TO THE CONVERSION OF A CRANE SHIP TO
HOST A BALLISTIC MISSILE DEFENSE TEST RADAR AND TELEMETRY
SYSTEM**

Michael E. Lash
Civilian, Missile Defense Agency, Redstone Arsenal, Alabama
B.S., North Georgia College, 1980

Submitted in partial fulfillment of the
requirements for the degree of

MASTER OF SCIENCE IN SYSTEMS ENGINEERING MANAGEMENT

from the

**NAVAL POSTGRADUATE SCHOOL
June 2010**

Author: Michael E. Lash

Approved by: Professor C. N. Calvano
Thesis Advisor

Dr. C. Whitcomb
Second Reader

Dr. C. Whitcomb
Chairman, Department of Systems Engineering

THIS PAGE INTENTIONALLY LEFT BLANK

ABSTRACT

Currently, all Missile Defense Agency (MDA) instrumentation radars are land-based at Reagan Test Site (RTS) in the Marshall Islands and the Pacific Missile Range Facility (PMRF) on the Hawaiian island of Kauai. The dependency on land-based radars produces significant gaps in radar coverage of planned ballistic missile defense system (BMDS) tests. The S.S. Beaver State is a former cargo ship that was converted to a crane ship. The purpose of a crane ship is to unload/load other ships at ports with inadequate facilities. When the Beaver State was converted to a crane ship, three large cranes were installed. The size of the ship and generators make the Beaver State suitable to host the first X-Band Test Radar (XTR-1) and the second Transportable Telemetry System (TTS-2). There are five major efforts in the conversion process: 1) Ship reactivation; 2) Modification of the ship to host the primary sensors, the adjunct systems, and the respective operators; 3) Installation and integration of the primary sensors and adjunct systems; 4) Development, installation, and certification of the communications system; and 5) Coast Guard certification. This thesis will review the history of the modification design and communications system development aspects of this conversion process, review the Department of Defense Architectural Framework (DoDAF), assess the applicability of DoDAF to the Beaver State conversion process, and suggest opportunities for improvement of similar MDA test asset development programs.

THIS PAGE INTENTIONALLY LEFT BLANK

TABLE OF CONTENTS

I.	INTRODUCTION.....	1
A.	BACKGROUND	1
B.	PURPOSE.....	4
C.	RESEARCH QUESTIONS.....	4
D.	BENEFITS OF STUDY.....	4
E.	SCOPE AND METHODOLOGY	4
1.	Scope.....	4
2.	Methodology	5
II.	HISTORY OF THE BEAVER STATE CONVERSION	7
A.	BACKGROUND	7
1.	MDA Flight Testing.....	7
2.	Some Other Sea-Based Sensor Platforms MDA Has Used to Support Testing.....	9
a.	<i>MV Pacific Collector.....</i>	10
b.	<i>Observation Island.....</i>	12
c.	<i>SBX.....</i>	13
3.	<i>Pacific Tracker Concept.....</i>	14
B.	PACIFIC TRACKER PROJECT	15
1.	Mission	15
2.	Organization.....	17
3.	Acquisition Approach.....	18
4.	Technical Approach.....	20
5.	Schedule and Milestones	22
6.	Design Evolution History	23
a.	<i>Acquisition Strategy Panel</i>	23
b.	<i>Systems Requirements Review.....</i>	24
c.	<i>Preliminary Design Review</i>	34
d.	<i>Critical Design Review.....</i>	35
e.	<i>Contract Award</i>	39
III.	REVIEW OF DODAF	41
A.	INTRODUCTION.....	41
B.	OPERATIONAL VIEW.....	43
C.	SYSTEMS VIEW.....	43
D.	TECHNICAL STANDARDS VIEW.....	44
E.	PRODUCTS.....	44
F.	DODAF SUMMARY	47
IV.	ANALYSIS OF THE APPLICABILITY OF DODAF TO THE PACIFIC TRACKER CONVERSION	49
A.	INTRODUCTION.....	49
B.	SELECTED <i>BEAVER STATE</i> CONVERSION DODAF PRODUCTS ...	49

1.	All View-1 Overview and Summary Information.....	49
2.	OV-1 High Level Concept Description	50
3.	OV-2 Operational Node Connectivity	51
4.	OV-3 Operational Information Exchange Matrix	56
5.	OV-4 Organizational Relationships	58
6.	OV-5 Operational Activity Model	63
7.	SV-1 System Interface Description.....	66
8.	SV-2 Systems and Services Communications Description and SV-6 Systems Services Data Exchange Matrix	67
C	CONCLUSIONS: POSSIBLE IMPACT OF DODAF ON THE PACIFIC TRACKER PROGRAM.....	69
V.	SOME IMPLICATIONS FOR OTHER MDA TEST ASSET DEVELOPMENT PROJECTS	73
	LIST OF REFERENCES	75
	INITIAL DISTRIBUTION LIST	77

LIST OF FIGURES

Figure 1.	The <i>S.S. Beaver State</i> as it is being towed from Suisun Bay Reserve Fleet in Benicia, CA to be temporarily berthed at Alameda, CA. (T. Amundsen, personal communication, 4 April 2008)	2
Figure 2.	The <i>MV Pacific Collector</i> . The twin 7m dishes of the Transportable Telemetry System are seen in the aft section of the ship (T-AGS-29, n.d.). ...	10
Figure 3.	USAV Worthy	11
Figure 4.	<i>Observation Island</i> : The S-Band phased array is seen on the aft deck, and the X-Band radar is seen atop the house, aft of the smokestack (USNS Observation Island, 2001).....	12
Figure 5.	Sea-Based X-Band Radar: The X-Band radar is under the large center dome (SBX, 2007).	13
Figure 6.	Organization of the Pacific Tracker and major sensors projects.	18
Figure 7.	Schedule for the project presented at ASP by DTR.....	23
Figure 8.	MARAD's power option 1.....	26
Figure 9.	Power option 2	27
Figure 10.	SRR power option 3.....	28
Figure 11.	TTS antenna configuration with 37 ft high radomes mounted on the main deck.....	31
Figure 12.	TTS antenna and deck configuration for option 2	32
Figure 13.	Option 3 with 42 ft tall radomes and antennas mounted on hatch coamings ..	32
Figure 14.	One line diagram of the power generation and distribution system presented at the CDR	36
Figure 15.	Interrelationships among DoDAF views	42
Figure 16.	DoDAF Products.....	46
Figure 17.	Architecture Products and their Applicability	47
Figure 18.	Pacific Tracker Overview and Summary Information.....	50
Figure 19.	Pacific Tracker High Level Concept Description.....	51
Figure 20.	OV-2 Operational Node Connectivity Description.....	53
Figure 21.	OV-2 Operational Node Connectivity Description Test Event Data.....	55
Figure 22.	OV-2 Operational Node Connectivity Description Test Event Voice.....	56
Figure 23.	OV-3 Operational Information Exchange Matrix with Test Event Data.....	57
Figure 24.	OV-3 Operational Information Exchange Matrix with Test Event Voice.....	58
Figure 25.	OV-4 Organizational Relationships August 2007	60
Figure 26.	OV-4 Organizational Relationships January 2009	61
Figure 27.	OV-4 Organizational Relationships, Possible End State Pacific Tracker.....	62
Figure 28.	OV-4 Organizational Relationships, Possible End State Pacific Tracker (Flight Test Operations).....	63
Figure 29.	OV-5 Operational Activity Model.....	65
Figure 30.	OV-5 Operational Activity during test execution.....	66
Figure 31.	SV-1 System Interface Description	67
Figure 32.	SV-2 Systems and Services Communications Description	68
Figure 33.	SV-6 Services Exchange Matrix.....	69

THIS PAGE INTENTIONALLY LEFT BLANK

LIST OF TABLES

Table 1.	MV Pacific Collector Specifications	11
Table 2.	USAV Worthy Specifications (Missile Range Instrumentation Ships, 2008)	12
Table 3.	USNS Observation Island Specifications (USNS Observation Island, 2001)	13
Table 4.	SBX specifications.....	14
Table 5.	Projected costs by FY for Pacific Tracker development and operation.....	19
Table 6.	Power requirements based on XTR-1 and TTS ICDs.....	25
Table 7.	APL summary conclusions for bandwidth requirements in kbs	33
Table 8.	MARAD's load analysis results.....	37

THIS PAGE INTENTIONALLY LEFT BLANK

EXECUTIVE SUMMARY

The conclusion of this thesis is the application of the Department of Defense Architecture Framework (DoDAF) to the design effort to convert a crane ship, *Beaver State*, to a range instrumentation ship would not have been very useful. The effort to convert *Beaver State*, to be re-named *Pacific Tracker*, has five major efforts: 1) Ship reactivation, *Beaver State* had been mothballed in the Department of Transportation, Maritime Administration's (MARAD) inactive reserve fleet; 2) Modification of *Beaver State* to host the Missile Defense Agency's X-Band Test Radar (XTR-1), one of its Transportable Telemetry Systems (TTS), adjunct systems, and respective operators; 3) Installation and integration of XTR-1, TTS, and adjunct systems; 4) Development, , installation, and certification of the communications system; 5) Coast Guard certification. The major engineering efforts in the conversion process that were considered in this thesis are: 1) The design of the modification for the ship to host the radar, telemetry, adjunct systems, and the respective operators; and 2) the design of the communications system. DoDAF with its emphasis on interoperability would not have significantly impacted the major ship modifications such as: modifications to house system operators; TTS placement, or electrical system modifications. Application of DoDAF to the communications system development would also not have a significant impact largely due to the evolutionary aspect of the communication system and the maturity of the established communication architecture.

This thesis reviews other ships, *Pacific Collector*, *Worthy*, *Observation Island*, and *SBX* which MDA has used for BMDS testing. Then the *Beaver State* conversion project history and DoDAF are reviewed. Next, sample DoDAF products that could have been produced for the *Beaver State* conversion are developed. The assessment is made that the application of DoDAF would not have been very useful to the project and DoDAF's utility for future MDA test asset developments would likely be similar. However, the development of DoDAF products relative to project organizations and processes did provide useful insights. The products OV-4 and OV-5, in particular, were useful. These products illustrated some complications with management of the project and operational processes.

THIS PAGE INTENTIONALLY LEFT BLANK

LIST OF ACRONYMS AND ABBREVIATIONS

ABS	American Bureau of Shipping
AOC	Aerospace Operations Center
APL	Applied Physics Laboratory
ASP	Acquisition Strategy Panel
AV	All View
BMDS	Ballistic Missile Defense System
BOA	Broad Ocean Area
CDR	Critical Design Review
CG	Coast Guard
CSC	Computer Sciences Corporation
DoDAF	Department of Defense Architecture Framework
DTR	Director Test Resources
DTRI	Division of Test Resource Infrastructure
EA	Executing Agent
FTG	Flight Test Ground-Based Interceptor
GIG	Global Information Grid
GMD	Ground-based Midcourse Defense
GPS	Global Positioning Satellite
HVPS	High Voltage Power Supplies
ICBM	Intercontinental Ballistic Missile
ICD	Interface Control Document
IR	Infrared
IRV	Inter-Range State Vector
KMRSS	Kwajalein Missile Range Safety System
KREMS	Kiernan Reentry Measurements Site
KV	Kill Vehicle
LOS	Loss of Signal
MARAD	Maritime Administration
MATSS	Mobile Aerial Target Support System
MDA	Missile Defense Agency

MIT/LL	Massachusetts Institute of Technology Lincoln Laboratory
MLP	Mobile Launch Platform
MRBM	Medium Range Ballistic Missile
MSC	Military Sealift Command
NGO	Non-Governmental Organization
NSWC	Naval Surface Warfare Center
OBIS	Observation Island
OV	Operational View
PC	Pacific Collector
PDR	Preliminary Design Review
PMRF	Pacific Missile Range Facility
PT	Pacific Tracker
PTL	Pacific Tracker Lead
PTPM	Pacific Tracker Project Manager
RD	Radar Development
RTS	Reagan Test Site
SAD	Situational Awareness Display
SATCOM	Satellite Communications
SBP	Sea-Based Platform Product Office
SBX	Sea-Based X-Band Radar
SOLAS	Safety of Life at Sea
SRBM	Short Range Ballistic Missile
SRR	System Requirements Review
SSDG	Ship Service Diesel Generator
SSTG	Ship Service Turbine Generator
SV	Systems View
TM	Telemetry
TMD	Theater Ballistic Missile Defense
TRM	Test Resource Manager
TTS	Transportable Telemetry System
TV	Technical Standards View
USAKA	U.S. Army Kwajalein Atoll

VAFB	Vandenberg Air Force Base
WSMR	White Sands Missile Range
XTR	X-Band Test Radar

THIS PAGE INTENTIONALLY LEFT BLANK

ACKNOWLEDGMENTS

I wish to thank all of my instructors. Each in their own way has been inspirational. I especially would like to acknowledge the PD21 program staff and my advisors for their assistance with this thesis. I also wish to thank my parents for the great start in life they gave me. Finally, most of all, I wish to thank my wife for walking with me during the challenges of the last few years. Without her support, none of this would have been possible.

THIS PAGE INTENTIONALLY LEFT BLANK

I. INTRODUCTION

A. BACKGROUND

The objective of the Pacific Tracker (PT) is to provide a ship with instrumentation quality radar and telemetry reception systems for data collection on Missile Defense Agency (MDA) flight tests. The MDA's mission is to develop systems to defend the U.S., our troops, and our Allies from ballistic missile attacks (Testing, 2007). The term "ballistic missile" covers a spectrum of systems. At one end of the spectrum are the Intercontinental Ballistic Missiles (ICBM) with ranges over 5,500 km. At the other end of the spectrum are the Short Range Ballistic Missiles (SRBM) with ranges as short as 80 km (NAIC 1998). This wide spectrum calls for flight test geometries that span tens of kilometers to thousands of kilometers between the target launch site and the interceptor's launch site.

Currently, all Missile Defense Agency instrumentation radars are land-based. Principally, these radars are located at the Ronald Reagan Ballistic Missile Defense Test Site (RTS) located on Kwajalein Atoll in the Marshall Islands and the Pacific Missile Range Facility (PMRF) on the Hawaiian island of Kauai. The dependency on land-based radars produces significant gaps in radar coverage of planned ballistic missile defense system (BMDS) tests. Historically, targets simulating Intercontinental Ballistic Missiles (ICBM) have been launched from Vandenberg Air Force Base (VAFB), in California, towards RTS. The distance between VAFB and RTS is nearly 5,600 km. While radar signature and metric data of the objects within the test scene are required throughout the trajectory, most of the trajectory is out of range or view of the land-based radars. It is this gap in coverage that motivates the need for ship-based sensors.

In this thesis, the term "radar signature data" refers to the radar derived data that is used to characterize an object so that it may be differentiated from other objects. Metric data refers to the motion and location of the object.

More recently, MDA has launched targets from Kodiak, an Alaskan island famous for its bears. MDA has also launched targets simulating Medium Range Ballistic Missiles (MRBMs) and SRBMs in various locations across the Pacific from U.S. Air Force C-17 aircraft and from the sea-based Mobile Launch Platform, the ex-USS Tripoli. Land on which to base a radar is simply not available in most cases. The mobile nature of the PT would allow MDA to greatly increase the radar and telemetry coverage on various tests locations across the Pacific. In order to meet data collection requirements, MDA has decided to convert the S.S. *Beaver State* to host the X-Band Test Radar (XTR-1) and the second Transportable Telemetry System (TTS-2). (The TTS-1 is currently installed on *MV Pacific Collector*.)



Figure 1. The S.S. *Beaver State* as it is being towed from Suisun Bay Reserve Fleet in Benicia, CA to be temporarily berthed at Alameda, CA. (T. Amundsen, personal communication, 4 April 2008)

S.S. Beaver State is a former cargo ship that was converted to a crane ship. The purpose of a crane ship is to unload or load other ships at ports with inadequate facilities. This sort of ship may be used to help put ashore a surge of materiel to support sustained combat operations. When *Beaver State* was converted to a crane ship, three large cranes were installed. To power the cranes, two 1200 kW diesel generators were also added. This size and number of generators are needed to reliably provide electrical power to the radar. The size of the ship and generators make *Beaver State* suitable to host the XTR-1 and TTS-2 systems and become *Pacific Tracker*.

In the course of converting *Beaver State* into *Pacific Tracker*, the large cranes will be removed and other modifications to the ship will be necessary to host the XTR-1 and the TTS-2. There are five major efforts in the conversion process:

1. Ship reactivation;
2. Modification of the ship to host the primary sensors, the adjunct systems, and the respective operators;
3. Installation and integration of the primary sensors and adjunct systems;
4. Development, installation, and accreditation of the communications system; and
5. Coast Guard certification.

The major engineering efforts in the conversion process that are considered in this thesis are: 1) The design of the modification for the ship to host the radar, telemetry, adjunct systems, and the respective operators; and 2) the design of the communications system. This thesis will review the history of these two aspects of this conversion process, review DoDAF 1.5, assess the applicability of DoDAF 1.5 to the *Beaver State* conversion process, and suggest opportunities for improvement of similar MDA test asset development programs.

B. PURPOSE

The purpose of this thesis is to: 1) Describe the conversion of SS *Beaver State* into SS *Pacific Tracker*, a project that did not incorporate DoDAF methodology; 2) Assess whether incorporating DoDAF would have improved the way the project was done; and 3) Provide recommendations on incorporating DoDAF into other MDA test asset development projects.

C. RESEARCH QUESTIONS

The following questions will be addressed in this thesis:

1. How was the *Beaver State* conversion project conducted?
2. What is DoDAF?
3. What DoDAF products might have been produced to support the project?
4. How may have the DoDAF methodology changed the way the project was done?
5. Would the DoDAF methodology have been useful to the project or be useful in future MDA test asset development projects?

D. BENEFITS OF STUDY

This thesis will document practical lessons derived from the *Beaver State* conversion. Recommendations will be provided on the application of the derived lessons to other MDA one of a kind, or few of a kind, test asset development.

E. SCOPE AND METHODOLOGY

1. Scope

The thesis will be limited to the applicability of DoDAF 1.5 to the design of the modifications for the ship to host the radar, telemetry, adjunct systems, and the respective operators; and the design of the communications system.

2. Methodology

The methodology used in this thesis research consists of the following steps:

1. Review other ships MDA has used for BMDS testing, and review project history of the conversion.
2. Review DoDAF.
3. Develop a sample of DoDAF products that could have been produced for the conversion.
4. Assess whether the DoDAF approach would have been useful to the project and its utility for future MDA test asset developments

THIS PAGE INTENTIONALLY LEFT BLANK

II. HISTORY OF THE BEAVER STATE CONVERSION

A. BACKGROUND

1. MDA Flight Testing

The MDA's mission is to develop systems to defend the U.S., our troops, and our Allies from ballistic missile attacks (Testing, 2009). Missile Defense flight tests are designed to provide the Ballistic Missile Defense System (BMDS) with test scenarios sufficiently similar to hostile conditions to ascertain or demonstrate BMDS performance against the threat. The term "threat" refers to the ballistic missiles of hostile or potentially hostile nations. The term "ballistic missile" refers to "Any missile that does not rely upon aerodynamic surfaces to produce lift and consequently follows a ballistic trajectory when thrust is terminated" (MDA Glossary, n.d.). Ballistic missiles include a variety of systems. The largest and longest ranged systems are the Intercontinental Ballistic Missiles (ICBM). For example, the Russian SS-18 Mod 5 has a range of over 9,600 km. The much smaller Russian SS-21 Mod 2, a Short Range Ballistic Missile (SRBM), has a range of only 75 km (NAIC 1998). In order to test BMDS against this wide variety of missile systems, flight test geometries often span hundreds of kilometers for the SRBM scenarios to thousands of kilometers for the ICBM scenarios.

The BMDS is "An integrated system that employs layered defenses to intercept missiles during their boost, midcourse, and terminal flight phases" (MDA Glossary, n.d.). Today's BMDS architecture includes satellites, radars, interceptor missiles, and battle management systems. The BMDS uses satellites and radars to detect and track threats once they have been launched. The battle management system uses track information from the satellites and radars to launch interceptor missiles toward the approaching threat. The interceptor missiles are designed to collide with and destroy the approaching threat missiles. A test scenario will often include a target missile launch towards the BMDS in such a manner as to simulate a hostile engagement.

To characterize a BMDS test, MDA collects information from a variety of instrumentation. Typical instrumentation includes radars, infrared imagers, visible imagers, and various sensors placed onboard the target missiles. Instrumentation radars are used to collect metric and signature data on the test scene to confirm the characteristics of the target missile and the threat scene presented to the BMDS. Various sensors placed onboard target missiles may include thermocouples and motion sensors that are designed to help characterize the target's performance. Data from the sensors onboard the target missiles are telemetered to surface receivers. In a similar manner, data from the interceptor missiles may also be telemetered to surface receivers.

Currently, all Missile Defense Agency instrumentation radars in the Pacific are land-based. The premier radars are part of the Kiernan Reentry Measurements Site (KREMS) at the Reagan Test Site (RTS) in the Marshall Islands (RTS, n.d.). Other significant radar assets are at the Pacific Missile Range Facility (PMRF) on the Hawaiian island of Kauai. The dependency on land-based radars can produce significant gaps in radar coverage of planned ballistic missile defense system (BMDS) tests, and to avoid data gaps, less realistic engagement test geometries might be used. Historically, targets simulating Intercontinental Ballistic Missiles (ICBM) have been launched from Vandenberg Air Force Base (VAFB) in California towards the U.S. Army Kwajalein Atoll (USAKA) Reagan Test Site (RTS) in the Marshall Islands. While signature and metric data are required along the entire length of the trajectory, with a ground track covering 5,600 km, most of the trajectory is out of sight and view of the land-based radars due to the curvature of the earth.

An instrumentation radar placed upon an appropriately positioned ship would close much of the gap in radar coverage in a VAFB to RTS trajectory. A ship-based radar could also provide greatly improved coverage of targets launched from Kodiak, Alaska and other locations in the Pacific. MDA has also launched target missiles simulating MRBMs and SRBMs in various remote locations across the Pacific. In addition to launching targets from land bases, MDA has also air- and sea-launched targets. MDA has used U.S. Air Force C-17 aircraft to air launch a target over the Pacific (News release 05-NEWS-0009, 2005). Near the Hawaiian island of Kauai, MDA has

used the Mobile Launch Platform (MLP), the ex-*USS Tripoli*. In June of 2008, MDA conducted a flight test off of Kauai where both the target and the interceptors were launched from vessels at sea. The target SRBM was launched from the MLP. Then, two interceptor missiles fired from the *USS Lake Erie* destroyed the target (Successful Sea-Based Missile Defense Intercept). MDA has requirements to collect radar data across the Pacific. A ship-based radar could have allowed MDA to greatly increase the radar coverage of these various test locations across the Pacific. MDA's solution to close many of the radar data collection gaps across the Pacific is the XTR-1 radar aboard the ship, *Pacific Tracker*.

2. Some Other Sea-Based Sensor Platforms MDA Has Used to Support Testing

The use of sea-based instrumentation to support flight testing is not a new concept. MDA has employed a number of instrumented sea-based platforms to support flight tests. These sea-based platforms include the *MV Pacific Collector*, the *USAV Worthy*, the Mobile Aerial Target Support System (MATSS), the *USNS Observation Island* (OBIS), and the Sea-Based X-band radar (SBX). None of these vessels were originally designed or built to support missile testing. Each vessel was designed and built for another function. However, in each case, the vessels were modified in order to accept the specialized instrumentation used in BMDS testing. The instrumentation on *Pacific Collector* and *Worthy* (Range Safety, n.d.) was developed and integrated on the ships specifically to support BMDS flight testing. MDA developed the SBX to be part of the operational BMDS (Testing, 2009). Even though the primary purpose of the SBX is not flight testing, MDA has been successful in collecting data with the SBX on MDA flight tests (News release 07-NEWS-0028, 2007). The MATSS and OBIS were originally developed for other related purposes. The PMRF developed MATSS to support naval weapons testing. The radars on OBIS are used to collect data on foreign ballistic missile tests (Cobra Judy, n.d.). However, the two systems, MATSS and OBIS, lend themselves well to supporting MDA flight tests.

a. *MV Pacific Collector*



Figure 2. The *MV Pacific Collector*. The twin 7m dishes of the Transportable Telemetry System are seen in the aft section of the ship (T-AGS-29, n.d.).

Pacific Collector (PC) is pictured in Figure 2. The ship is the former *Texas Clipper II*, a school ship for the Texas A&M University maritime program. Prior to serving as a school ship, the vessel was the *USNS Chennault* (T-AGS-29, n.d.). The MDA engaged the Maritime Administration (MARAD) to manage the modification and operation of the *Texas Clipper II*. Shortly after the modification, the *Texas Clipper II* was renamed *Pacific Collector*. The installation of the Transportable Telemetry System-1 (TTS-1) soon followed in late 2006. The twin 7m dishes and control shelters can be seen on the aft section of the PC. The PC was developed specifically by MDA to perform flight test telemetry data collection in the broad ocean area (BOA) where telemetry assets were not otherwise available. The PC and TTS-1 system have collected data successfully on several missions since late 2006. The current home port for the PC is Portland, Oregon.

DISPLACEMENT	5,360 T
LENGTH	393 ft
BEAM	54 ft
DRAFT	31 ft
PROPULSION	2 ALCO 251 V-12 DIESEL ENGINES, SINGLE SHAFT, 3,400 SHP

Table 1. *MV Pacific Collector Specifications*



Figure 3. USAV Worthy

The *USAV Worthy*, pictured in Figure 3, is the former Stalwart Class Ocean Surveillance Ship *USNS Worthy* (USNS Worthy, n.d.). The U.S. Army Kwajalein Atoll (USAKA) acquired the ship in 1995 and installed the Kwajalein Missile Range Safety System (KMRSS) “to support TMD related remote site launch activities” (Range Safety, n.d.). TMD in this case stands for Theater Ballistic Missile Defense. The

primary purpose of the KMRSS is to terminate powered flight of an errant missile. The KMRSS uses redundant dishes to receive S-Band telemetry data from the missile. The data includes the missile's position, velocity, heading, and other factors. This data is then processed to predict an impact point. If the calculated impact point threatens a protected area, then a command is sent over UHF to terminate thrust (Range Safety, n.d.).

DISPLACEMENT	2,262 LT
LENGTH	224 ft
BEAM	43 ft
DRAFT	15 ft
PROPULSION	4 Caterpillar 398D

Table 2. *USAV Worthy Specifications (Missile Range Instrumentation Ships, 2008)*

b. Observation Island



Figure 4. *Observation Island*: The S-Band phased array is seen on the aft deck, and the X-Band radar is seen atop the house, aft of the smokestack (USNS Observation Island, 2001).

The ship was originally launched in 1953. The Navy acquired the ship three years later for use as a fleet ballistic missile test ship. OBIS was kept in reserve from 1972 to 1977 before it was converted to a missile range instrumentation ship. Observation Island is currently operated by the Military Sealift Command (MSC) for the U.S. Air Force Technical Applications Center. The ship is host to S-Band phased array radar and X-Band dish radar. The OBIS is used for “worldwide, monitoring compliance with strategic arms treaties and supporting U.S. military weapons test programs” (Missile Range Instrumentation Ships, 2001). The radars are collectively known as COBRA JUDY (Cobra Judy Radar System, n.d.).

DISPLACEMENT	17,015 LT
LENGTH	564 ft
BEAM	76 ft
DRAFT	28 ft
PROPULSION	Steam, 7180.25 kW

Table 3. *USNS Observation Island Specifications (USNS Observation Island, 2001)*

c. SBX



Figure 5. **Sea-Based X-Band Radar: The X-Band radar is under the large center dome (SBX, 2007).**

The Sea-Based X-Band Radar (SBX) is unique for its physical design but also because it is part of the operational BMDS (Testing, 2009). The twin-hulled vessel is based on a fifth-generation self-propelled, semi-submersible oil drilling platform. The top of the dome is over 280 ft. above the keel. The powerful radar “can be positioned to cover any part of the globe” (SBX, 2007). The SBX is able to support BMDS testing; however, it is part of the operational BMDS. As part of the BMDS, it is designed to track and discriminate between a hostile warhead and possible decoys (SBX, 2007).

DISPLACEMENT	~50,000 T
LENGTH	390 ft
BEAM	240 ft
DRAFT	133 ft
PROPUSION	4 Siemens 3401.387 kW Electric Motors

Table 4. *SBX specifications*

3. *Pacific Tracker Concept*

The concept behind *Pacific Tracker* is to place a test range instrumentation quality radar, comparable to radars at USAKA, on a ship that can be positioned anywhere in the Pacific. Such flexibility would provide radar coverage on BMDS flight test scenarios that now have significant gaps due to the distance from land-based test range instrumentation radar assets.

Data from such a radar would be valuable for multiple reasons. One is to characterize test events. For example, a radar can be used to determine the time-dependent position and motion of various test objects, associated hardware, and debris. The test objects may include the mock warhead of an offensive missile, possible decoys, and the interceptor kill vehicle (KV). Associated hardware may include spent rocket motors and hardware that is dispersed when rocket stages separate or test objects are deployed. Debris may include hot chunks of combustion by-products ejected from solid rocket motors or the fragments produced by an intercept event. While systems utilizing

Global Positioning Satellite (GPS) are able to produce data sufficiently accurate to be used to determine position and motion of many larger objects, many objects are too light or small to carry the equipment necessary to support transmitting GPS derived metric data.

In order to meet the radar data collection requirements, MDA developed the X-Band Test Radar (XTR-1) with the intent to place the radar on a suitably sized ship. The XTR-1 is a dual, X and S, band radar with an 11m dish antenna. After the Pacific Tracker program was started, MDA/DTR decided to add the other Transportable Telemetry System (TTS-2) to *Pacific Tracker*. TTS-2 is a duplicate of the TTS-1 on *Pacific Collector*, also with dual 7m dishes.

B. PACIFIC TRACKER PROJECT

1. Mission

The mission of the Sea-Based Platform Product Office (SBP) is to maintain, operate, and develop sea-based platforms to support MDA flight test activities. The SBP was initially formed in July 2007. The first two platforms in SBP's portfolio were the telemetry collection ship *Pacific Collector* and the Mobile Launch Platform (MLP). The MLP is the ex-USS *Tripoli*, a former Iwo Jima class amphibious assault ship. The primary function of the MLP is to serve as a launch platform for target missiles, similar to Scuds, for BMDS testing. The MLP is operated as a live-aboard barge and is towed by the former fleet tug, *Narragansett*. With the completion of the 24 August 2007 Acquisition Strategy Panel (ASP), DTR assigned the development effort, *Pacific Tracker*, to the SBP. Responsibility for the ship passed from the Radar Product Branch to the SBP.

The initial tasking of the SBP was to finalize ship selection and convert the selected ship to accommodate the XTR-1 radar. Once *Beaver State* was selected, the SBP had to complete five major efforts to convert *Beaver State* to *Pacific Tracker*. The five major efforts in the conversion process are: 1) Ship reactivation; 2) Modification of the ship to host the primary sensors, the adjunct systems, and the respective operators; 3)

Installation and integration of the primary sensors and adjunct systems; 4) Development, installation, and certification of the communications system; and 5) Coast Guard certification. This thesis is primarily centered on the utility of DoDAF for the ship modifications necessary to host the radar and the development of the communications system. The five major efforts are described in more detail below.

1. Ship reactivation: Covers all actions to return the ship to sea-worthy condition. Based upon the ASP decision, the ships considered for conversions were all U.S. government-owned and mothballed in the inactive fleet. Mothballed is used here to describe measures taken to protect the ship and equipment from corrosion or deterioration. At a minimum, the preservation measures needed to be removed and the equipment returned to operating condition. Repairs would be needed to address deficiencies in the ship's condition at the time of the mothballing and to address deficiencies resulting from deterioration that occurred while mothballed. Part of the ship selection process took into account the overall condition of the ships.

2. Modification of the ship to host the primary sensors, the adjunct systems, and the respective operators: The ship selected for conversion would require modifications to accommodate the primary sensors, XTR-1 and TTS-2. Modifications necessary to support XTR-1 include: electrical distribution, a foundation for the radar antenna, and a control/computer room. Because the TTS-2 had already been built and the XTR was being assembled, the first approach was to have the XTR and TTS programs develop respective interface control documents (ICDs). Then the ship modifications would be designed to match the ICDs.

This was the approach taken for installing the TTS-1 temporarily on the MLP and then permanently on *Pacific Collector*. The TTS was designed to be a self-sufficient system needing only a relatively flat piece of land or deck to sit on. It had its own power system, SATCOM system, control room, and antenna base. This was not the case with the XTR-1. XTR-1 had requirements for power, SATCOM, control room, and antenna base. The XTR-1 could not simply be bolted on the ship. Significant changes had to be made to the ship to accommodate the XTR-1.

3. Installation and integration of the primary sensors and adjunct systems: This phase is when the sensors are brought to the ship and installed. It also includes the time necessary to restore the sensors to working condition once installed on *Pacific Tracker*.

4. Development, installation, and accreditation of the communications system: Initially the communication system was seen to be part of the XTR; however, with the addition of the TTS-2, this effort shifted to SBP to work. The initial concept primarily centered on test range communications and data transmission. As requirements for test range communications and data transmission were developed, requirements necessary to support XTR and TTS operations and maintenance surfaced. Accreditation of the communication system also became an issue because the Tracker had to interface with other DoD assets on the Global Information Grid (GIG).

5. Coast Guard (CG) certification: Prior to a ship being authorized to sail, it must be in a condition that meets Coast Guard regulations. The CG certification process generally consists of a series of inspections by the CG or the American Bureau of Shipping (ABS). “A tax-exempt non-governmental organization (NGO), ABS has been commissioned by the U.S. government and the USCG to act in many maritime matters that relate directly to the safety of life and property at sea” (ABS Fact Sheet, 2005).

2. Organization

The SBP at the start of the project consisted of two individuals: the government project manager and one contractor employee. The project manager had experience with leading prior MDA test asset development efforts. These previous efforts were focused on the development of an infrared (IR) imaging sensor and extensive modification of aircraft to host the new IR sensor. The contractor employee, a retired Navy skipper, had extensive experience with ships. The organization was typical of project management in that the Pacific Tracker Project Manager (PTPM) was not anybody’s supervisor and had almost no formal contractual control. He was able to restrict the flow of money; however, that was only the coarsest form of control. The PTPM provided funding directly to three organizations: Johns Hopkins University/Applied Physics Laboratory

(JHU/APL), NSWC Corona Division, and MARAD HQ. The bulk of the funding, roughly 97%, went to MARAD. MARAD and NSWC received funds via Military Interdepartmental Purchase Request (MIPR). MDA had a contract with JHU/APL, and the PTPM was the task manager for that contract.

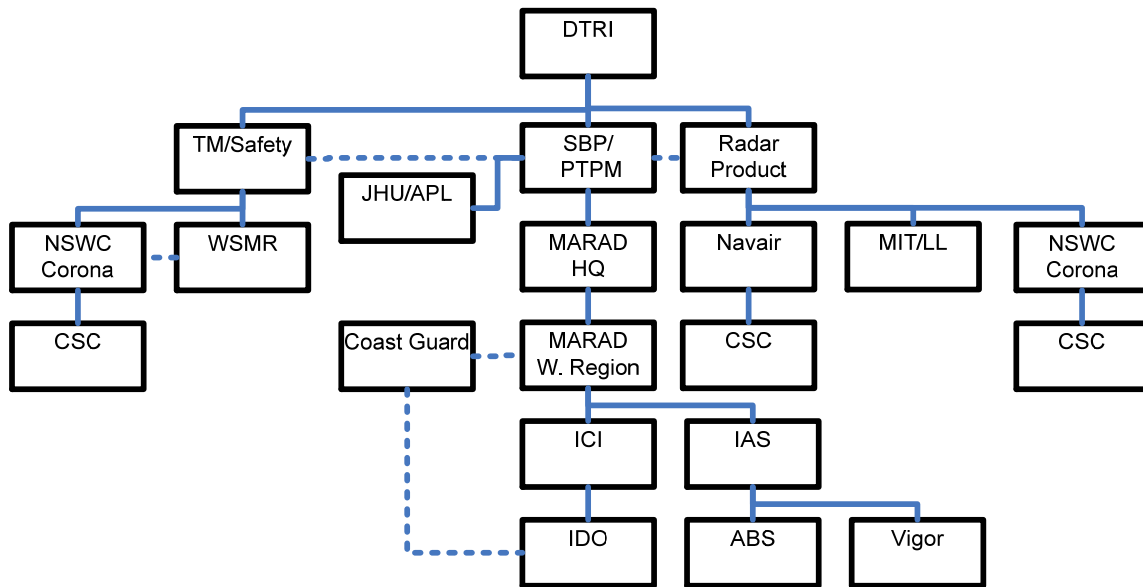

Figure 6. Organization of the Pacific Tracker and major sensors projects.

The PTPM assigned JHU/APL to provide detailed engineering analysis, as needed, and to provide systems engineering to support to the Pacific Tracker development efforts. The Radar Development Branch selected NSWC Corona to develop the communications system for the XTR-1 mission equipment. Corona was experienced with integrating SATCOM with MDA test assets. Corona had developed the SATCOM system linking TTS-1 and TTS-2 and successfully revamped the SATCOM on the MLP to name two projects. MARAD was assigned to make recommendations for the ship selection; to re-activate the ship; to modify the ship; and to gain CG certification.

3. Acquisition Approach

MDA considered several approaches for acquiring a ship to become *Pacific Tracker*. Among the approaches considered were a new acquisition—designing and

building a new special purpose ship; drawing a ship from the U.S. Inactive Reserve Fleet (which is also sometimes referred to as the MARAD option); or a lease arrangement with a ship owner/operator. MDA/DTR considered designing and building a special purpose ship and quickly deemed the expected costs to be too high based upon a recent Navy contract award. The Navy had recently selected the design and build new approach for its Cobra Judy replacement program. In 2006, the Navy made a “\$199M contract award for the design and construction” (VT Halter, 2006) of a new ship based upon the existing T-AGS 39 design. The \$199M price tag for the Cobra Judy replacement far exceeded MDA’s budget for *Pacific Tracker*. MDA considered two options in more detail: 1) drawing a ship from the U.S. Inactive Reserve Fleet and 2) a lease arrangement with a ship owner and operator.

The acquisition of *Pacific Collector* followed the approach of drawing a ship from the U.S. Inactive Reserve Fleet. Given the success of *Pacific Collector*, MDA embarked on the same approach with *Pacific Tracker*. While MARAD was conducting the initial assessment of available ships in the inactive reserve fleet for MDA, Edison Chouest (an offshore vessel services company) approached MDA with the Lease option. Edison Chouest proposed to modify one of their vessels to support XTR requirements and then operate the ship for MDA under a ten-year lease. Once MARAD had completed the initial assessment, MDA performed a business case analysis of the three options in the summer of 2007. The results are shown in Table 5. The Director, Test Resources presented these results to MDA’s Acquisition Strategy Panel (ASP) on 24 August 2007.

Estimator	Total Ship Outlays (\$M)		FY08	FY09	FY10	FY11	FY12	FY13	Total FYDP	FYDP Savings vs. Lease (\$M)
DOBE	MARAD Options	Beaver State	12.7	13.0	21.4	21.8	22.2	22.7	113.8	28.6
		Diamond State	13.6	15.1	21.4	21.9	22.3	22.8	117.1	25.3
	New Ship (8500 LTns)		97.0	148.8	21.0	21.5	21.9	22.4	332.6	
	Lease (based on Edison Chouest)		16.5	24.1	24.7	25.2	25.7	26.2	142.4	

Table 5. *Projected costs by FY for Pacific Tracker development and operation*

As shown in Table 5, MDA’s procurement group estimated MDA’s costs for the three approaches to develop and operate *Pacific Collector*. Additionally, within the MARAD option, two different ships were considered. DOBE estimated that the design,

conversion, and XTR integration would occur within FY08 and FY09. These estimates allowed time for the sensor integration but did not include costs for the XTR integration or operation. These costs were included when the ASP previously considered and approved the XTR program independent of ship platform. The costs for the remaining years are projected maintenance, berthing, and operation. The operational costs are based on eight data collection voyages. The duration of each voyage was assumed to be 21 days.

MDA's procurement group analysis determined that the New Ship approach was the most costly approach by a wide margin and supported DTR's early rejection. The Lease approach did not appear to offer any great advantage above the MARAD approach. The Lease approach had the higher initial cost, higher operational cost, and of course, the higher total cost. The Lease option Edison Chouest proposed possibly offered the advantage of fixed, known costs with the contractor assuming the risk. The fixed cost option was only possible if the requirements were fully known and not likely to change in a significant manner--an unlikely scenario for the Pacific Tracker project. MARAD had concluded that two crane ships, *Beaver State* and *Green Mountain State*, were best suited to meet MDA requirements. *Beaver State* and *Green Mountain State* were similar though not identical ships and either one could meet the MDA requirement to host the XTR. The difference in projected cost for the conversion and activation phase of the program was driven by the difference between the physical conditions of the two ships. *Beaver State* was judged by MARAD to be best in class.

4. Technical Approach

The technical approach for the Pacific Tracker program was largely determined by the acquisition decision to pull a ship from the inactive reserve and modify it to meet the requirements of hosting the XTR. At the ASP, some discussion was given to the ability of candidate ships to host a TTS. However, the ability to host the TTS was not identified as a formal requirement until after the ship selection. The formal requirement at the time of the ASP was to find a ship with the size and electrical power generation capability to accommodate only the XTR.

At the time of the ASP briefing, the technical approach had four major steps. The first step was for the XTR-1 developer, Massachusetts Institute of Technology Lincoln Laboratory, to produce an interface control document (ICD). “MIT Lincoln Laboratory is a federally funded research and development center chartered to apply advanced technology to problems of national security” (MIT/LL, n.d.). The second step was for naval architects, under contract to MARAD, to develop a design in accordance with the XTR-1 ICD. The third step was for a shipyard to make the modifications to the ship. The fourth step was for the XTR to be integrated on the ship, once the shipyard work was completed. As the program progressed, TTS-2 and the communications system were added to the effort. The steps for TTS and the communications system followed a path of requirements definition, design, modification, and installation similar to XTR-1.

The first step of developing the ICD was expected to be straight forward for the developer. The XTR-1 was in a relatively advanced stage of development and it already was being fabricated. The XTR-1 ICD was expected to describe the interfaces between the radar and the ship as well as identify other requirements for space, electrical power, and cooling for the radar.

Likewise, the second step was expected to be straight forward for the naval architects to produce a design to host the radar. It was envisioned that the naval architects would quickly produce a detailed design. There were three major components of the design: the electrical system, structural modifications, and machinery (predominantly a chilled water system to cool the radar). It was understood that the electrical system would have to be modified to allow the radar to draw power from either diesel generator. Structural modifications that included building out rooms such as office spaces and control and computer rooms were expected to be relatively simple. While a larger effort, even the structural modifications foundation for the XTR antenna was considered to be straight forward. It was thought the design of chilled water cooling system was largely a matter of selecting the correctly sized commercial system.

Once the modification design was complete, the third step was to compete the modification work among interested shipyards and have the winning shipyard perform the modifications. The modifications would be coupled with dry-dock work in the

competitive package. The dry-dock work would be routine items necessary to activate the ship and meet regulatory requirements. After the shipyard completed the modifications and work in the dry-dock, the fourth step would be to install the XTR-1 on *Pacific Tracker*.

5. Schedule and Milestones

The initial schedule that was shown during the ASP briefing is shown in Figure 7. Figure 7 shows *Pacific Tracker* milestones in relation to upcoming FTGs. FTG is the designation for flight tests of the Ground-based Midcourse Defense (GMD) system. FTG scenarios include the Vandenberg to Kwajalein trajectories. The first milestone is the authority to proceed with ship acquisition. The date coincides with the ASP presentation on 24 August 2007. At that time, the XTR-1 schedule showed that the radar would be ready to install on the ship towards the end of FY 2008. The detail design work prior to entering into the shipyard was scheduled to begin September 2007 and run approximately six months to the end of February 2008. This allowed only six months for MIT/LL to produce an ICD and for MARAD to produce the detailed design to modify the ship to allow it to accept the XTR. The next six months were allotted to shipyard modifications of the vessel. Then another six months were allotted for the installation of the radar on the ship. After another month of sea trials, *Pacific Tracker* would be ready to support FTG-08.

Phase	FY07	FY08	FY09	FY10	FY11	FY12	FY13
Upcoming FTGs	03a ★	04 05 06 ★ ★ ★	07 08 ★ ★	09 10 ★ ★	11 ★		
Ship Acquisition Authority to Proceed	▲						
Radar Ready for Ship Platform		▲					
Detailed Design Work		■ 6 months (01 Sept '07 – 29 Feb '08)					
Reactivation and Modification			■ 6 months (01 March '08 – 31 Aug '08)				
Radar Integration Onto Ship			■ 6 months (01 Sept '08 – 28 Feb '09)				
Sea-Based Acceptance Testing			■ 1 Month (01 Mar '09 – 31 Mar '09)				
XTR-1 Ready to Support Missions			▲				
Operations and Sustainment			■				

Figure 7. Schedule for the project presented at ASP by DTR

6. Design Evolution History

The design requirements for *Pacific Tracker*, and hence the corresponding design concepts, underwent significant changes as the project proceeded. A few significant milestones in the program are used to capture the then current design requirements and design concepts at those particular junctures. The first milestone will be the ASP meeting. Subsequent milestones will be SRR, CDR, and contract award. Between milestones, the design made significant changes due to requirement changes, improved understanding of requirements, and cost constraints.

a. Acquisition Strategy Panel

At the time of the ASP, MIT/LL had yet to develop its ICD. There was sufficient understanding of the requirements for electrical power and physical size to select a ship. However, those requirements were not sufficiently understood for the naval architects to begin a detailed modification design. Several months after the ASP, two additional major requirements were added to the program. First was the addition of TTS-

2 and the second was for XTR-1 to operate throughout a flight without loss of data, even with a prime power causality. The impacts of those requirements are discussed in more detail in the following section on the Systems Requirements Review.

b. Systems Requirements Review

At the SRR, options were presented for modifications to the ship to provide: mission equipment electrical power, MDA mission personnel berthing, TTS antenna placement, and the communications system. In this thesis, the term “mission equipment” is used to denote the equipment associated with the XTR, TTS, and communications system. Between the ASP and the SRR, there were two major changes to *Pacific Tracker* requirements. The first was the addition of the TTS. The second major change was the clarification of the requirement to supply reliable power to the mission equipment. The power requirement was now to have the mission equipment, including the radar on UPS backup, sufficient to power the system for 30 minutes. The addition of TTS to the ship added not only new requirements to support the installation of the TTS equipment but also placed additional demands on berthing, the communication system, and the electrical system. While the addition of TTS drove changes to the electrical design, the requirement to supply reliable electrical power to the mission equipment was the biggest driver. (The primary source of information for the systems requirements review section is the March 2008 Trade Studies presented by the PTPM at the SRR.)

The overarching requirement for the electrical system is to reliably meet the mission equipment’s power demand throughout the flight event. Prior to the addition of TTS, the XTR ICD indicated it would draw about 1280 kVA, including communications, when it was radiating at full mission load. The TTS ICD indicated its load would be another 320 kVA. The resulting total mission equipment load would be 1600 kVA. The power generation capability seemed to be more than enough to meet the mission equipment’s expected load.

System	Total
XTR-1	1,265 kVA
TTS-2	320 kVA
Comms	15 kVA
Grand Total	1,600 kVA

Table 6. *Power requirements based on XTR-1 and TTS ICDs*

Beaver State has the capability to generate 3900 kW. She has two 750 kW steam turbine generators and two 1200 kW diesel generators. After taking into account the ship's expected load of about 600 kW, there would still be 3300 kW available to power the mission equipment. The power generation capability for the generators is expressed in kW; however, the load is expressed in kVA. A conversion is required to express the power and the load in the same units. The MARAD electrical design engineer selected a power factor of 0.8. Therefore, the 1600 kVA load converts to 1280 kW. The addition of TTS increased the mission equipment's load by 25%. However, the generation capability was well over two times the expected load.

The "reliably...throughout the flight event" portion of the requirement produced a more significant impact than adding the TTS load. "Throughout the flight" meant from shortly before the first launch until the last splash. For ICBM intercept tests, this translates to a time period of about 30 minutes. The intent was for XTR, TTS, and the communications system to remain fully functional, that is with no loss of data, for 30 minutes even if the respective primary power source was lost. MARAD developed three options to meet the power requirement: 1) Modify the switchboard so both diesel generators operate in parallel; 2) Add a third diesel generator; and 3) Add an uninterruptable power supply (UPS) sufficient to power all of the mission equipment for 30 minutes of operations.

Option 1, as shown in Figure 8, has the following features: 1) Lowest cost of the options considered; 2) If one steam turbine generator or one diesel generator fails (after missile launch), the UPS units will provide continuity of mission equipment power for 30 minutes; and 3) Failure of either a diesel generator or diesel generator switchboard

will not interrupt power to S and X-Band High Voltage Power Supplies (HVPS) and XTR Antenna Servo Motors. The major disadvantage is that it did not meet management's desire to have all the mission equipment backed up by a UPS.

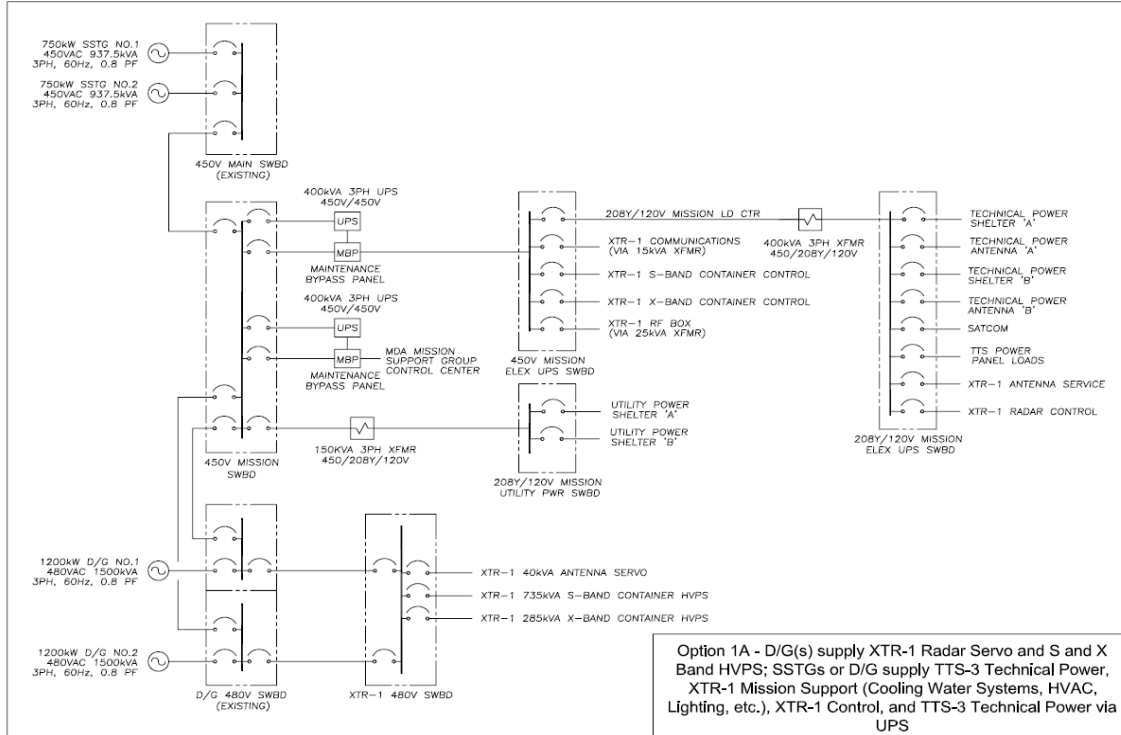

Figure 8. MARAD's power option 1

Option 2, as shown in Figure 9, has the following features: 1) Failure of any diesel generator or diesel generator switchboard will not interrupt mission power. The remaining diesel generator can maintain mission power without having to rely on UPS units; 2) The mission power system is completely isolated from the ship's power system. Disruptions in the ship's power system will not affect mission operations; and 3) According to MARAD, a 1640 kW diesel generator was currently available from another MARAD activity. The disadvantages of this option are: 1) It is the most expensive of all the options; 2) It requires new auxiliary machinery room and associated support systems for the diesel generator installation and a new diesel generator switchboard; and 3) Additional engine room watch personnel would be required.

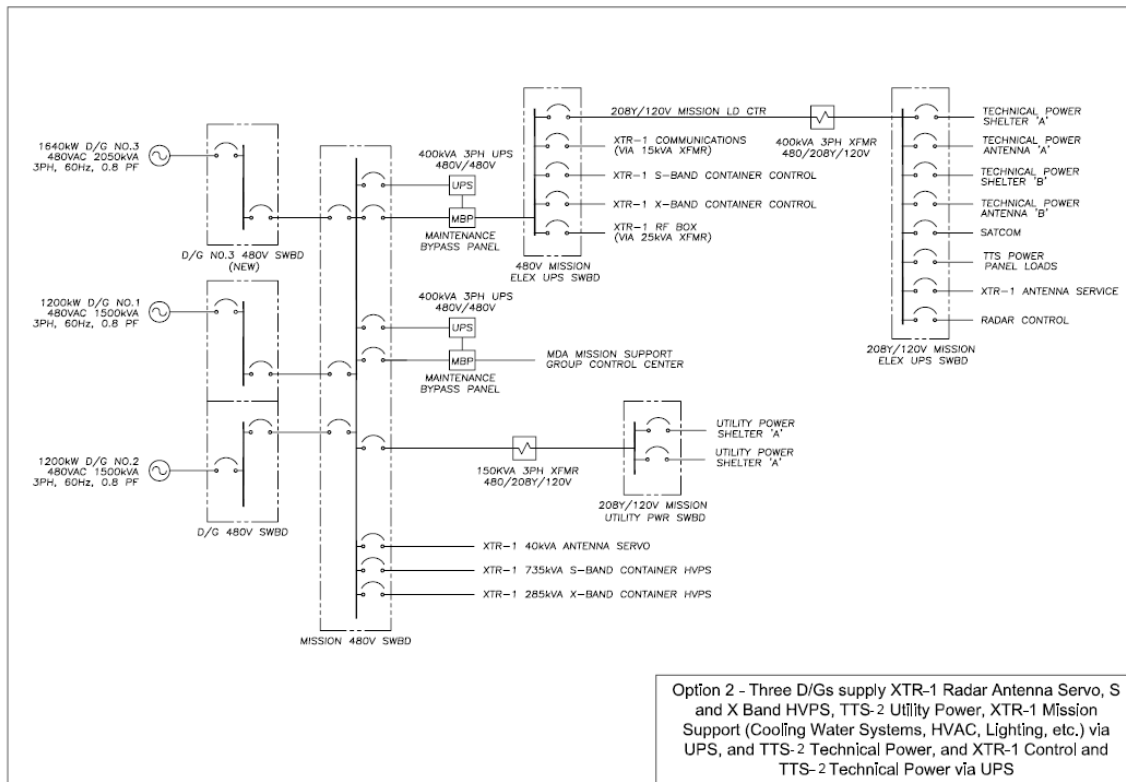

Figure 9. Power option 2

Option 3, as seen in Figure 10, has the following features: 1) Failure of any (or both) diesel generator will not interrupt mission power for a minimum of 90 minutes, and 2) The mission power system is completely isolated from the ship's power system. Disruptions in the ship's power system will not affect mission operations. The disadvantages of option 3 are: 1) It requires installing a new diesel generator switchboard and Mission Switchboard, and four 400 kVA UPS units; and 2) Different voltages of the ship's service power system, 450 V, and Mission power systems, 480 V, prevent the capability to parallel systems. Significant modifications are necessary to permit paralleling to the ship's service switchboard and SSTG governors; and 3) The UPS battery life expectancy will likely cause new batteries to be purchased every few years.

DT management considered the power options and projected costs. After some additional discussion, DT management decided to relax the requirement for 100% UPS backup for all mission equipment. When the requirement was changed from 100%

UPS backup to 100% backup, option 1 became viable. This option uses one of the diesel generators as the primary power source and the other diesel generator as the back up power source for the radar transmitters. Additionally, option 1 uses UPS as the back up power source for the other mission equipment. DT management directed the program to proceed with refining option 1.

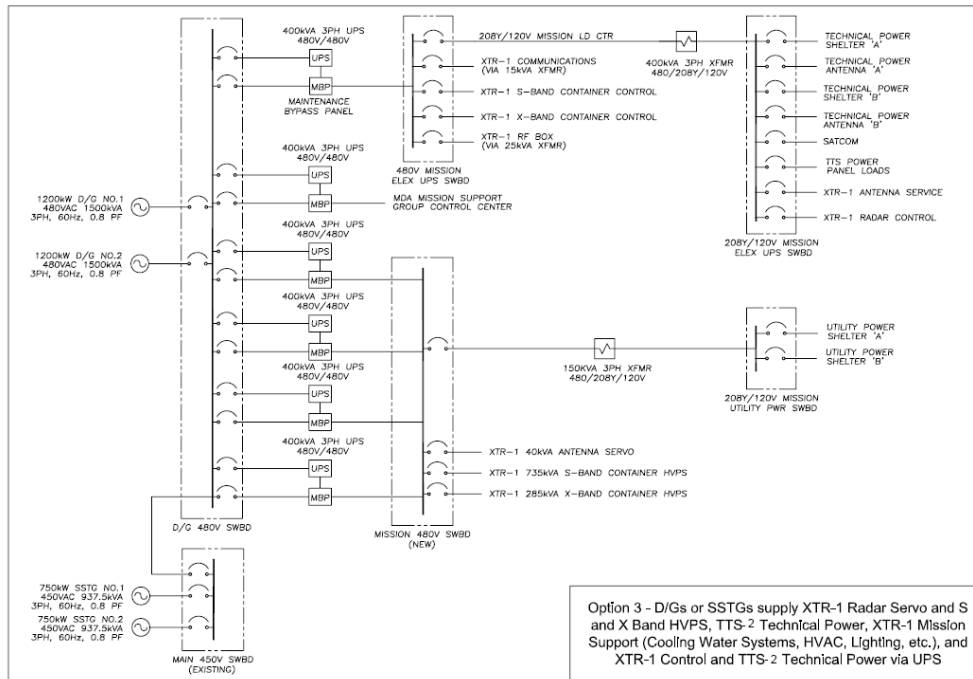

Figure 10. SRR power option 3

Options for berthing were also presented at the SRR. There are not enough berthing rooms onboard the ship to provide every member of the ship's crew and MDA mission crew with a private room. If each member of the ship's crew had a private room, there would only be enough state rooms to accommodate eight MDA personnel, not the currently expected 22–29 personnel. MARAD developed three options to accommodate additional personnel. The first option is to utilize the existing staterooms without building additional staterooms. The second option is to install 24 new single staterooms and utilize six single staterooms currently existing within the ship's house. The third option was to install 30 new single staterooms.

The first option is to use the existing 22 single and 21 double staterooms without building additional staterooms. The ship's crew requires 12 single staterooms for the licensed and senior unlicensed personnel. For the remaining unlicensed personnel, they will be assigned to 14 double staterooms. The remaining ten single and seven double staterooms would be assigned to MDA mission personnel. This would allow MDA to place 24 personnel onboard.

There are a number of issues associated with these limits. The first issue is the use of only the existing staterooms severely constrains the staffing flexibility for both MDA and MARAD. MDA will be restricted to only 24, just two more than the lower limit. The ship's crew will be limited to 40. Previously, when *Beaver State* was active, she steamed with a crew of 39. The size of the ship's crew had yet to be determined. The improved viewing, because the large cranes will no longer restrict the view from the bridge, may reduce the crew size by three, according to MARAD. However, the added MDA mission crew will likely increase the required number in the steward department. These numbers do not account for gender. For example, if there were seven males and seven females in the MDA crew whose status would normally place them in a double room, only one odd male or odd female could be berthed but not both. The option of only using existing staterooms does have the advantage of having the lowest cost of the three options.

The second option was to build accommodations on the main deck in front of the house. These new accommodations would provide 24 new single staterooms for MDA mission personnel. This option also called for MDA to utilize another six single staterooms in the house. This would have allowed space for 30 MDA mission people and allowed the ship's crew to reach a level of 35 before having to double bunk anyone. This option met the requirements; however, it did place limits on MDA's flexibility. The issue with this option and the third option was cost. MARAD's cost estimate for building the 24 new staterooms was \$5M.

The third option presented called for the building of 30 new staterooms for MDA mission personnel. This would have provided MDA with enough berthing to meet its expectations and no one on the ship's crew would have to double up. There even

would have been some vacant rooms to allow for contingency or additional sensors. This option would provide better living conditions for high ops tempo and would provide the most flexibility for staffing the ship and the MDA mission systems. The down side was the cost. By MARAD's estimate, the incremental cost was only \$500k more for 30 staterooms over the 24 stateroom plan. The recommendation was to go with option 3.

The initial plan for the TTS-2 antenna installation was to place them on the hatch coamings in the open. This concept was very similar to how the TTS-1 antennas are mounted on *Pacific Collector*. However, DT leadership clarified the TTS requirement to include radomes over the antennas. Leadership mandated the use of radomes in order to improve the lifecycle maintainability of the TTS-2's antennas. The issue with the radomes was that nothing could be allowed to block visibility for the wheel house. The visibility requirement is "...the view of the sea surface is not obscured forward of the bow by more than the lesser of two ship lengths or 500 meters (1,640 feet) from dead ahead to 10 degrees on either side of the vessel. Within this arc of visibility any blind sector caused by cargo, cargo gear, or other permanent obstruction must not exceed 5 degrees." (Construction and Arrangement, 2004). Even the introduction of the shortest feasibly sized radome would exceed the allowable limits of obstruction if placed on top of the hatch coaming.

The TTS developer initially provided a radome design that called for a height of 42 ft. With further discussions and analysis the TTS developer and the naval architect determined the maximum feasible height for the radomes to be 37 ft. A height of 37 ft could be achieved; however, there would be regrets for the TTS operators. Even so, the 37' tall radomes placed on the hatch coaming would have blocked the view from the bridge. Therefore, three options, in addition to the no radome option, were developed to explore methods to allow heights of 37, 39, and 42 feet.

Three options were presented to meet the combined requirements for visibility from the bridge and protecting the antenna: 1) Limit the radomes to a height of 37 feet; remove hatch coamings, and modify the ship's main deck; 2) Limit the radomes to a height of 39 feet; raise the wheel house one level; and partially modify the ship's deck; and 3) Raise the wheel house two levels; without modifications to the ship's deck.

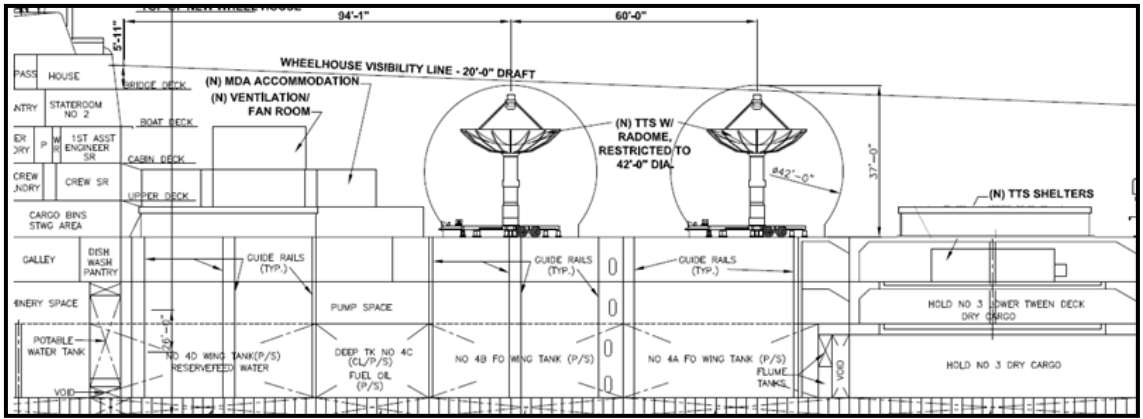

Figure 11. TTS antenna configuration with 37 ft high radomes mounted on the main deck

MARAD’s first option has the advantage of being the lowest cost option which would allow radomes of any size. Nevertheless, it would call for an estimated \$2.4M to remove the hatch coamings and build deck inserts strong enough to support the TTS antennas. As shown in Figure 12, the front radome would still produce a partial obstruction. This obstruction, however, would be within the allowable limits. The forward antenna was brought as far aft as possible to maintain a required 60 ft separation between antennas.

The second option would allow a greater separation between antennas and a radome height of 39 ft. It would have also only called for the removal of one hatch coaming and the corresponding deck insert. However, it called for the wheel house to be raised one level, approximately 8 ft. This may have seemed to be the compromise option; however, it was the costliest of the three. While it combined the advantages, higher radome height, and less steel work on the main deck, it also combined the cost of major steel work on the main deck and the cost of raising the wheel house.

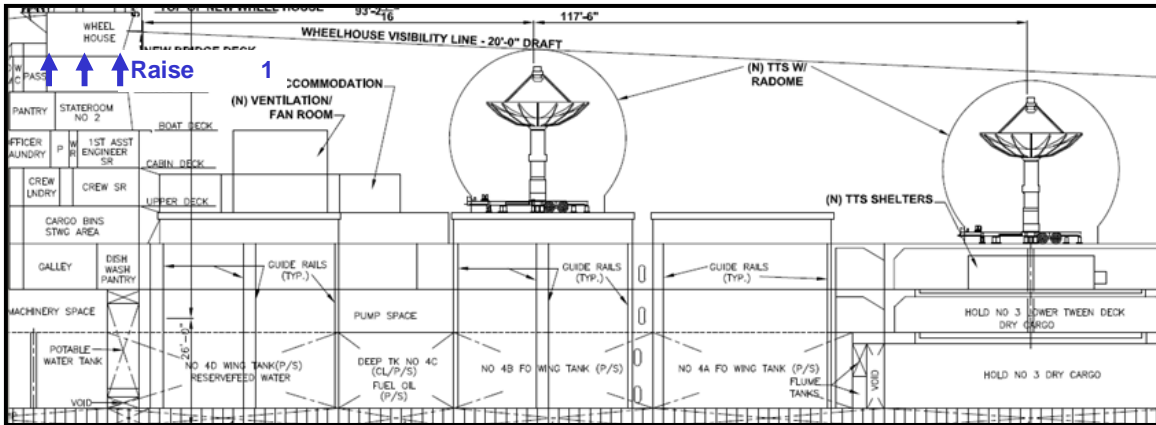

Figure 12. TTS antenna and deck configuration for option 2

The third option allowed for the full sized radomes, 42 ft, and it avoided major room steel work on the main deck. No hatch coamings would have to be removed; however, the wheel house would now have to be raised two levels, or 16 ft. The cost for option 3 was estimated to be \$5M. DT management directed that option 1 for the TTS antennas be implemented.

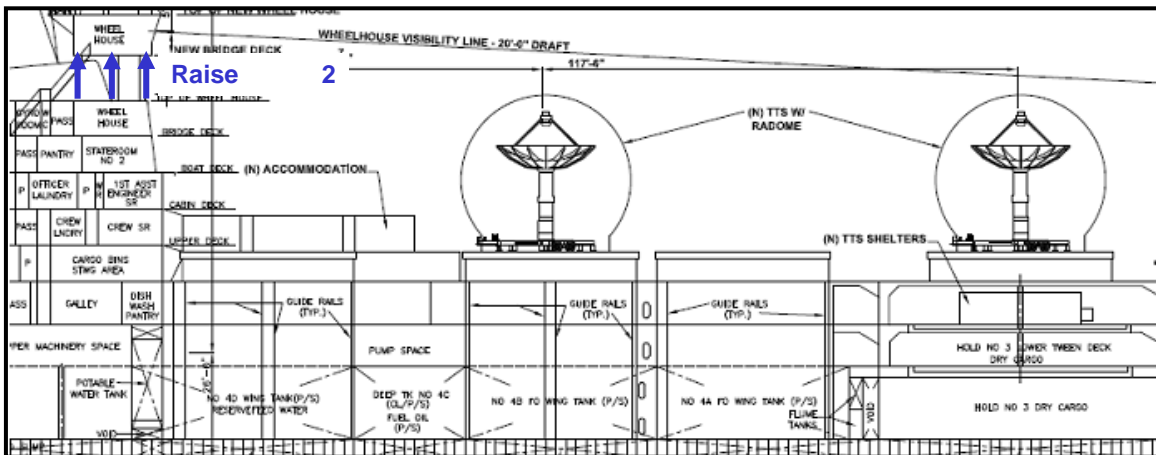

Figure 13. Option 3 with 42 ft tall radomes and antennas mounted on hatch coamings

The XTR and the TTS have requirements to receive and transmit data. For example, both systems will require the ability to receive and send pointing data in the form of an inter-range state vector (IRV). In addition, it is highly desirable to send processed data from the systems in real time as they track objects during the test event.

PTPM directed APL to conduct a study to determine the MDA mission requirements for communication. This study did not address the communication equipment needed for ship operations. Their summary conclusion is shown in Table 7.

Phase	Direction	Critical	Medium*	Low*
Pre-Mission	Incoming	198	1745	2855
	Outgoing	175	1668	2750
During Mission	Incoming	198	1315	2718
	Outgoing	175	4333	6535
Post-Mission	Incoming	45	1038	1918
	Outgoing	45	2873	5348
Pier Side	Incoming	0	2238	6048
	Outgoing	0	2238	6048

* Cumulative totals (include higher priority traffic)

Table 7. *APL summary conclusions for bandwidth requirements in kbs*

APL recognized that the communication traffic would change as the system progressed from one phase of the test cycle to the next. The direction of the traffic, whether incoming or outgoing, needs to be considered along with the priority of the traffic. The test event activity was split into four phases: Pre-Mission, During Mission, Post-Mission, and Pier Side. The term During Mission refers to the time frame beginning roughly eight hours prior to the beginning of the launch countdown until several minutes after the flight test event. Pre-Mission is the time frame between leaving the pier and the start of the During Mission phase. Post-Mission is the time between the end of the test event and the ship arriving back at Portland. Pier Side is the time when *Pacific Tracker* is berthed at home port. Incoming traffic means the data flow from shore to the sensors. Outgoing traffic means the data flow from the sensors to the shore. APL used three levels of priority: Critical, Medium, and Low. Critical priority traffic means the traffic critically necessary to achieve the primary test event objectives, relative to the

XTR and TTS. Examples of this type of traffic are the inter-range vectors used to cue sensor tracking. Without these tracking cues, the ability of the XTR and TTS to autonomously acquire and track a target is not assured. Medium priority traffic is needed to support a certain function. For example, Medium traffic would be providing real time data, such as video from the booster sent via telemetry or XTR console display to the test range or other sites. This could also include such general support as phone and fax traffic. Low priority traffic is useful to support a certain function. However, without this traffic, the function would still work. For example, Internet access may fall into this category. None of the sensors are dependent on the Internet to function correctly; however, access to the Internet for information may help the operations (Zheng, 2008).

The existing communications equipment from TTS-2 includes three Fleet 77 INMARSAT and one wideband Sea Tel 2.4 m dish. The TTS had been configured so that the critical data had two paths: the Fleet 77 INMARSATS and the Sea Tel. The medium and low priority traffic only followed over the Sea Tel. While this configuration was sufficient for TTS alone, it did not allow enough bandwidth for the TTS and XTR critical data. The PTPM presented three options to address the shortfall: 1) one Sea Tel and four INMARSATS; 2) two Sea Tel systems; 3) two Sea Tels and three INMARSATS. The first option called for purchasing additional Fleet 77 INMARSAT and integrating the one Sea Tel and four INMARSATs onto the Tracker. Option 2 called for purchasing a second Sea Tel and installing only the two Sea Tels. The third option called for the purchase of a second Sea Tel as in option 2; however, the three existing INMARSAT would also be installed as a tertiary backup for the systems. DT management directed option 2 be pursued.

c. Preliminary Design Review

At the PDR, MARAD showed some further details on the designs presented at the SRR, except for the electrical design. The general arrangement for the placement of XTR-1 and TTS-2 had not changed. However, as MARAD's naval architects refined the designs, additional questions surfaced. Between the SRR and the PDR, the naval architects had taken a much closer look at the XTR-1 requirements for the

antenna foundation. Significant amount of discussion between the naval architects and the XTR-1 developers ensued to better understand the stated requirements. The naval architects initially approached the foundation design from a traditional mechanical load perspective, for example, determining what mechanical loads, weight, torque, and so forth must the foundation support. However, the specifications MIT/LL had provided were in terms of stiffness, and in particular, required the foundation not to conduct vibration, which would excite the natural resonance frequency of the XTR-1 antenna pedestal.

d. Critical Design Review

During the progression from the SRR to the CDR, the power requirements became better understood and the power margin shrank. The MARAD design team became more concerned about the margin. MARAD completed a load analysis. The load analysis determined there was still enough power; however, the predicted mission equipment load had significantly increased from the early indications. The predicted mission equipment load had increased so much the design for the power system had to be changed. The concept at the SRR was for the SSDGs to supply primary and backup power for the radar antenna servos and S and X band high power voltage power supplies. For simplicity in this section, the radar antenna servos and S and X band high power voltage power supplies are referred to as simply, “the radar.” The other mission equipment, TTS-2; XTR-1 control; communications equipment; and mission support equipment (cooling water, HVAC, lighting, and so forth), would be powered by the SSTGs with backup power being provided by the UPS and the other SSDG. (The primary source of information for the critical design review section is the Aug 2008 Post-CDR briefing presented by the PTPM to DT management following the CDR.)

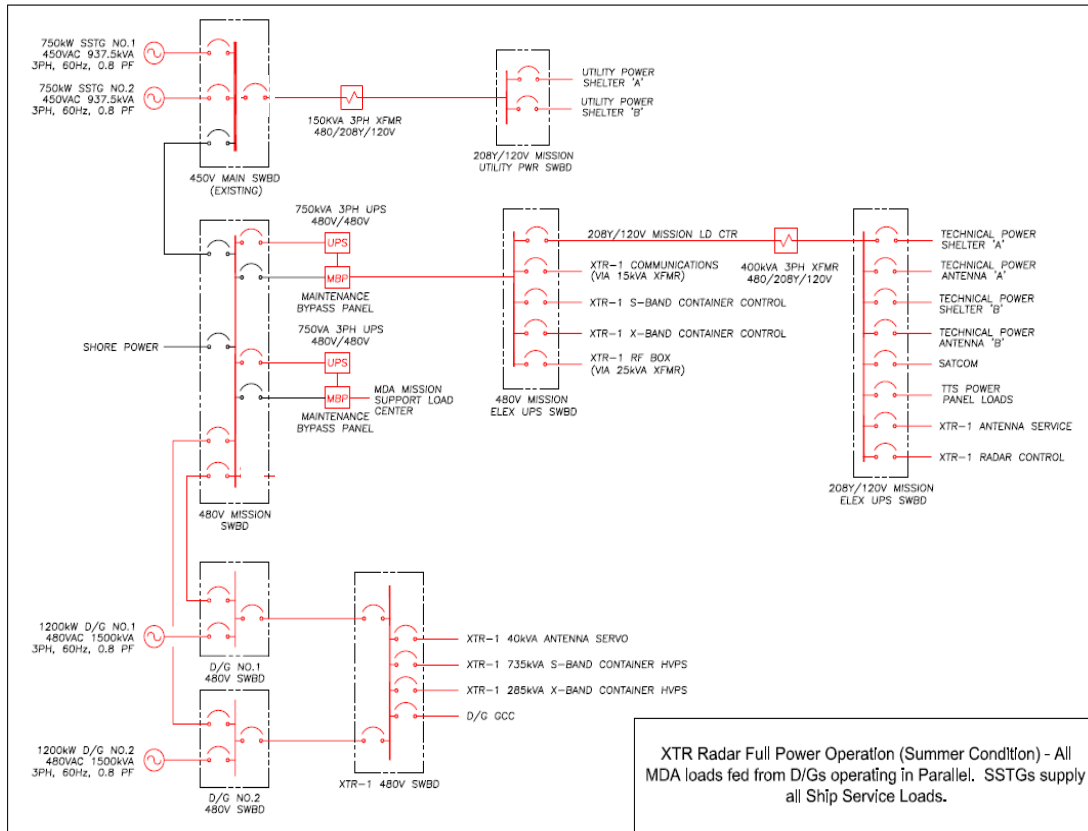

Figure 14. One line diagram of the power generation and distribution system presented at the CDR

System	Radar On Max kVA	Radar Off Max kVA
XTR-1		
Radar	1,060	-
Technical	145	145
Utility	13	13
Total XTR-1	1,218	158
TTS-2		
Technical	169	169
Utility	144	144
Total TTS-2	313	313
Mission Support		
Chilled Water	658	434
HVAC	88	88
Diesel Load	104	-
Total Mission Support	850	522
Grand Total		
	2,381	993

Table 8. *MARAD's load analysis results*

At the CDR, it was clear that the expected loads for the other mission equipment were too large for the SSTGs to supply when the radar was operating. The SSTGs could supply sufficient power to the other mission equipment when the radar was not in operation. By operating, it is meant that generating RF energy would either be transmitted or converted into heat in devices known as dummy loads. The cooling necessary while the radar is operating is too much for the SSTGs along with the other mission equipment. When the radar is in operation, both SSDGs are necessary for power. One SSDG is required to power the radar and one SSDG is required to power the other mission equipment. Now, when the power system is configured for radar operation, if the SSDG powering the radar fails, the other SSDG must shed the other mission equipment load and switch to power the radar. The other mission equipment has to rely on the UPS for power. In a similar fashion, when the power system is configured for radar operation and if the SSDG powering the other mission equipment were to fail, the other mission equipment has to rely on the UPS for power. In this case, the other SSDG would continue to power the radar.

Two other significant changes were made to the power system design. The size of the UPSs were increased and the utility power for the TTS shelters was moved off the Mission Support UPS and over to the SSTGs. The two 400 kVA UPSs in the SRR concept had to be increased to 750 kVA each. The maximum load on the clean power UPS was expected to be 336 kVA while the maximum load on the mission support UPS had grown to 745 kVA. The predicted load on the clean power UPS did not increase much from the SRR. The predicted load on the mission support UPS had a significant increase. In particular, the chilled water and HVAC were the biggest factors which drove the power requirements. Both UPSs did not have to increase to the 750 kVA size. The clean UPS could have easily stayed at 400 kVA. However, the decision was made to keep the UPSs identical with the expectation of reducing the cost of critical spares that must be kept onboard the ship. One may note the total load is not evenly spread over the two UPSs.

The load is not more evenly split because of the type of loads. The compressors and other equipment on the Mission Support UPS are considered to be fairly noisy. And, that equipment does not require clean power as the mission electronics will. The Mission Electronics UPS provides power conditioning for the equipment attached behind it from equipment attached on the front side. It protects the Mission Electronics from noisy loads such as the radar's high power voltage power supplies and compressors. This is why the TTS utility power was not shifted over to the Mission Electronics UPS even though there is more than enough margin left on the Mission Electronics UPS to accommodate the TTS utility power. The TTS utility power was shifted off the Mission Support UPS because the predicted load on that UPS had grown so large. The load on the Mission Support UPS provided motivation to move the TTS utility power off that UPS and because the noisy equipment described as TTS Utility could produce problems for the equipment powered by the other UPS. Thus, the decision was made to instead shift the load in question to the SSTGs.

This decision avoided the need to go to an even larger or third, smaller UPS. The decision also, however, made the mission equipment more dependent on the SSTGs. Table 8 indicates that both SSTGs are needed to fully supply utility power for

the TTS shelters. This leaves the TTS Utility equipment without an instantaneous source of backup power. Not providing TTS Utility equipment with instantaneous backup was judged to be acceptable for several reasons. The loss of HVAC and lighting does not instantaneously stop the TTS data collection. Depending on ambient temperature conditions, the TTS may be able to operate 30 minutes without HVAC. Analysis also indicated that the ship's crew would be able to shed enough of the ship's load to allow the TTS utility equipment to come back on line prior to degradation of the data collection. Because of the conservatism in calculating the predicted load, the second SSTG may not actually be needed.

No new designs for the crew berthing were presented. After the SRR, MARAD evaluated several other options for adding additional rooms. None of the options resulted in a significant cost savings over what had been considered at the SRR. The number of staterooms for the MDA mission crew did not change; however, it was determined that three of the rooms that had been counted as single, because of how they had been previously used, were actually double staterooms. Therefore, the allowable number of MDA mission personnel increased by three and now stood at 27, just two less than the stated requirement of 29.

e. Contract Award

The work package in the bid request was consistent with the design at CDR. Only one bid was received. Because the cost of the bid was much higher than expected, the work package was reduced to fit into available funding. Of the items discussed in this thesis, the major design change was to place the TTS antennas on top of the hatch coamings. Several months after the shipyard work began, additional funding was identified, and the contract was modified to revert to the TTS placement per the CDR design.

THIS PAGE INTENTIONALLY LEFT BLANK

III. REVIEW OF DODAF

A. INTRODUCTION

This chapter discusses the Department of Defense Architecture Framework (DoDAF). Except as otherwise cited, all quotes and figures in this chapter are taken from the DoD Architecture Framework Version 1.5 Volume I: Definitions and Guidelines 23 April 2007. The term architecture is in common usage usually applies to the structure or appearance of a building. Because architecture is applied to more than buildings, it is important to establish what is meant by architecture. Architecture, in this paper, is the “structure of components, their relationships, and the principles and guidelines governing their design and evolution over time” (DoDAF Version 1.5 v I). With this definition, the architecture still applies to the form and function of buildings and also to such diverse entities such as software, organizations, and military systems. The Defense Science Board has determined that standardized architecture descriptions are vital for ensuring interoperable and cost effective military systems (USD(A&T), ASD(C3I), J6, 1997). “An architecture description is a representation of a defined domain, as of a current or future point in time, in terms of its component parts, how those parts function, the rules and constraints under which those parts function, and how those parts relate to each other and to the environment.” (DoDAF Version 1.5, v I)

Interoperability describes how well entities function and work together. More formally, interoperability is defined as “The ability of systems, units, or forces to provide data, information, materiel, and services to and accept the same from other systems, units, or forces and to use the data, information, material, and services so exchanged to enable them to operate effectively together” (DAU Glossary). As competition for resources and complexity of systems increases, so does the need to make sure all of the pieces function and work together. The probability of extraneous or poorly integrated components increases with the system’s complexity. The DoD can ill afford the cost of inefficiencies

produced by extraneous or poorly integrated components. To help ensure interoperable and cost effective military systems, the DoD has established DoDAF to describe DoD system architectures.

The DoDAF is an evolution of the 1997 Command, Control, Communications, Computers, Intelligence, Surveillance, and Reconnaissance (C4ISR) Architecture Framework. The DoDAF's purpose is to provide guidance for describing warfighting operations and business operations and processes, not just C4ISR systems. The DoDAF does not provide guidance on how to construct or implement a specific architecture or how to develop and acquire systems. The framework provides rules, guidance, and product descriptions for developing and presenting architecture descriptions. The principal objective of the framework is to make sure architecture descriptions of DoD systems can be related and compared throughout DoD, across service and even multi-national boundaries. Common principles, assumptions, and terminology address this objective. The DoDAF specifies three views that combine to describe the architecture. The three are Operational View (OV), Systems View (SV), and Technical Standards View (TV). Figure 15 (DoDAF Version 1) illustrates the relationships between the three views.

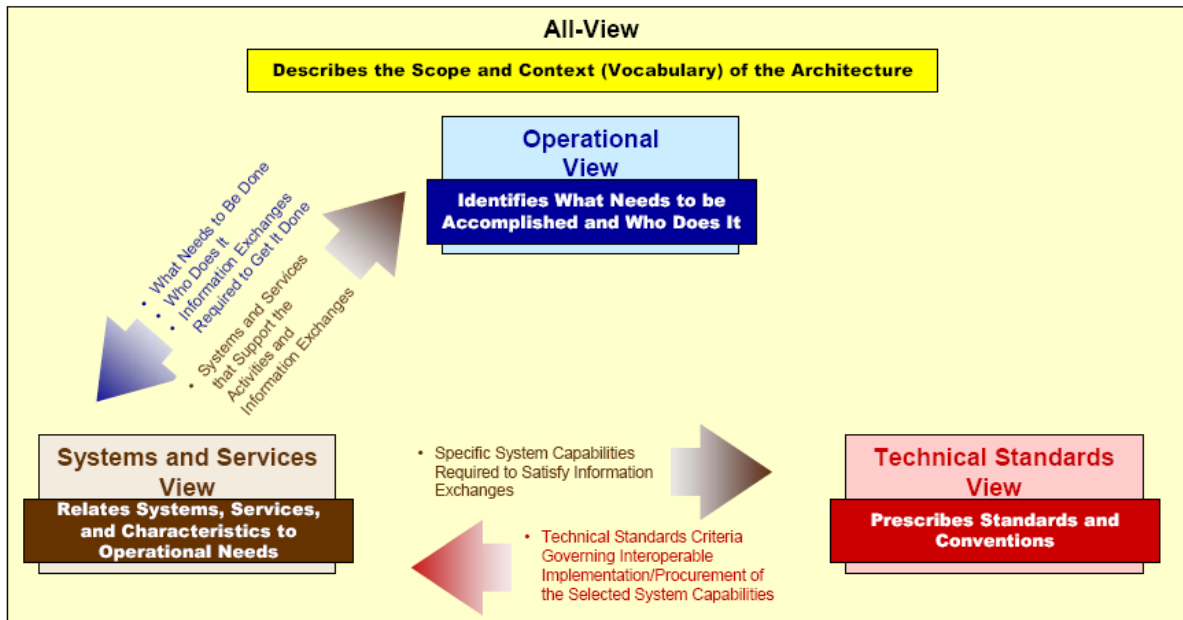

Figure 15. Interrelationships among DoDAF views

B. OPERATIONAL VIEW

The OV is a description of the mission, warfighting, and other entities that need to be supported by the system. It describes what is going on with the system in the field. The OV contains textual and graphical products that identify the elements, assigned operations, and information flow between elements. This view reveals requirements for capabilities and interoperability. OV descriptions are useful for DoD wide assessments to examine business processes, technology insertion, or doctrinal and policy implications, to name a few.

Usually the OV of a system is doctrine-driven. However, outside forces can cause a system or organization to operate in a manner inconsistent with doctrine. In these cases, the OV can be very useful to determine if doctrine changes are in order or if the root cause is some other factor such as lack of supporting infrastructure or information. Ideally, an OV is independent of materiel. However, new technologies may influence or push elements, assigned operations, and information flow between elements. For this reason, some high-level SV products or data elements may be needed to support information in the OV products.

C. SYSTEMS VIEW

The SV describes the existing and future systems and physical interconnections that support the mission documented in the OV. As used in DoDAF, a system is defined as “any organized assembly of resources and procedures united and regulated by interaction or interdependence to accomplish a set of specific functions” (DoDAF Version 1.0). The SV is used to address specific systems. This can include current, developing, or conceptual technologies, depending on the purpose for developing the architecture. The level of detail in the SV will depend on the purpose for developing the architecture. Architectures are developed for a variety of reasons. DoDAF users may develop Systems Views to describe the system’s current state, to assist in transitioning to a new state, or to analyze future options.

D. TECHNICAL STANDARDS VIEW

The DoDAF defines TV as the smallest set of rules overarching the interaction, interdependence, and arrangement of system parts or elements. This view is used to ensure that a system meets particular operational requirements. The TV provides the technical guidelines on which the engineering specifications are based, products are developed, and common building blocks are recognized. This view additionally augments the SV with forecasts of standard technology evolution.

E. PRODUCTS

The DoDAF also defines 29 architecture products, which are organized into All Views, OV, SV, and TV. Figure 16 provides a list of architecture products (DoDAF Version 1.5). The DoDAF Version 1.5 also provides specific guidance on which architecture products are applicable for various uses of architecture descriptions. This is shown in Table 2 (DoDAF Version 1.5).

Applicable View	Framework Product	Framework Product Name	Net-Centric Extension	General Description
All View	AV-1	Overview and Summary Information	✓	Scope, purpose, intended users, environment depicted, analytical findings
All View	AV-2	Integrated Dictionary	✓	Architecture data repository with definitions of all terms used in all products
Operational	OV-1	High-Level Operational Concept Graphic	✓	High-level graphical/textual description of operational concept
Operational	OV-2	Operational Node Connectivity Description	✓	Operational nodes, connectivity, and information exchange need lines between nodes
Operational	OV-3	Operational Information Exchange Matrix	✓	Information exchanged between nodes and the relevant attributes of that exchange
Operational	OV-4	Organizational Relationships Chart	✓	Organizational, role, or other relationships among organizations
Operational	OV-5	Operational Activity Model	✓	Capabilities, operational activities, relationships among activities, inputs, and outputs; overlays can show cost, performing nodes, or other pertinent information
Operational	OV-6a	Operational Rules Model	✓	One of three products used to describe operational activity—identifies business rules that constrain operation
Operational	OV-6b	Operational State Transition Description	✓	One of three products used to describe operational activity—identifies business process responses to events
Operational	OV-6c	Operational Event-Trace Description	✓	One of three products used to describe operational activity—traces actions in a scenario or sequence of events
Operational	OV-7	Logical Data Model	✓	Documentation of the system data requirements and structural business process rules of the Operational View
Systems and Services	SV-1	Systems Interface Description Services Interface Description	✓	Identification of systems nodes, systems, system items, services, and service items and their interconnections, within and between nodes
Systems and Services	SV-2	Systems Communications Description Services Communications Description	✓	Systems nodes, systems, system items, services, and service items and their related communications lay-downs
Systems and Services	SV-3	Systems-Systems Matrix Services-Systems Matrix Services-Services Matrix	✓	Relationships among systems and services in a given architecture; can be designed to show relationships of interest, e.g., system-type interfaces, planned vs. existing interfaces, etc.
Systems and Services	SV-4a	Systems Functionality Description		Functions performed by systems and the system data flows among system functions
Systems and Services	SV-4b	Services Functionality Description	✓	Functions performed by services and the service data flow among service functions
Systems and Services	SV-5a	Operational Activity to Systems Function Traceability Matrix		Mapping of system functions back to operational activities
Systems and Services	SV-5b	Operational Activity to Systems Traceability Matrix		Mapping of systems back to capabilities or operational activities
Systems and Services	SV-5c	Operational Activity to Services Traceability Matrix	✓	Mapping of services back to operational activities
Systems and Services	SV-6	Systems Data Exchange Matrix Services Data Exchange Matrix	✓	Provides details of system or service data elements being exchanged between systems or services and the attributes of that exchange

Applicable View	Framework Product	Framework Product Name	Net-Centric Extension	General Description
Systems and Services	SV-7	Systems Performance Parameters Matrix Services Performance Parameters Matrix	✓	Performance characteristics of Systems and Services View elements for the appropriate time frame(s)
Systems and Services	SV-8	Systems Evolution Description Services Evolution Description	✓	Planned incremental steps toward migrating a suite of systems or services to a more efficient suite, or toward evolving a current system to a future implementation
Systems and Services	SV-9	Systems Technology Forecast Services Technology Forecast	✓	Emerging technologies and software/hardware products that are expected to be available in a given set of time frames and that will affect future development of the architecture
Systems and Services	SV-10a	Systems Rules Model Services Rules Model	✓	One of three products used to describe system and service functionality—identifies constraints that are imposed on systems/services functionality due to some aspect of systems design or implementation
Systems and Services	SV-10b	Systems State Transition Description Services State Transition Description	✓	One of three products used to describe system and service functionality—identifies responses of a system/service to events
Systems and Services	SV-10c	Systems Event-Trace Description Services Event-Trace Description	✓	One of three products used to describe system or service functionality—identifies system/service-specific refinements of critical sequences of events described in the Operational View
Systems and Services	SV-11	Physical Schema	✓	Physical implementation of the Logical Data Model entities, e.g., message formats, file structures, physical schema
Technical Standards	TV-1	Technical Standards Profile	✓	Listing of standards that apply to Systems and Services View elements in a given architecture
Technical Standards	TV-2	Technical Standards Forecast		Description of emerging standards and potential impact on current Systems and Services View elements, within a set of time frames

Figure 16. DoDAF Products

Applicable Architecture Product Data																						
Uses of Architecture Data	All View		Operational View (OV)					Systems and Services View (SV)						Tech Stds View								
	1	2	1	2	3	4	5	6	7	1	2	3	4	5	6	7	8	9	10	11	1	2
Analysis & Assessment																						
Capabilities																						
- Gaps/Shortfalls					⊙		●						●	●								
- Mission Effects & Outcomes, Operational Task Performance	●	●	●	●	●	⊙	●		●	●				●	●				●	⊙		
- Trade-Offs	●	●	●	●	●	●	●	●	●	●			●	●	●	●			●	⊙	●	⊙
- Functional Solutions	●	●	●	●	●	●	●	●	●	●			●	●	●	●			●	⊙	●	⊙
Operations																						
- Process Re-engineering	●	●		●	●		●	●														
- Personnel & Organizational Design	●	●	●	●	●	●	●	●	⊙	⊙	⊙	⊙			⊙							
- Doctrine Development/Validation	●	●	●	●	●	●	●	●														
- Operational Planning (CONOPS and TTPs)	●	●	●	●	●	●	●	●		●	⊙	⊙	⊙	⊙							⊙	
Systems/Services																						
- Communications	●	●								●	●	●							⊙		●	⊙
- Interoperability and Supportability	●	●	●	●	●	⊙	●	●	⊙	●	⊙		●		●	⊙	●		⊙	●	●	⊙
- Evolution/Dependencies	●	●								●	●	●	●	●	●	●			●	●	●	●
- Materiel Solutions Design & Development	●	●		●	●		●	●	⊙	●	●	●	●	●	●	●	⊙	⊙	⊙	⊙	⊙	⊙
- Facilities Packaging	●	●		●			●	●		●	●	●	●	●							●	⊙
- Performance							●	●						●		●				●		⊙
Socialization/Awareness/Discovery																						
- Training	●	●	●	●	●	●	●	●	●	●	●	⊙	⊙	⊙	⊙							
- Leadership Development	●	●	●	●		●	⊙	●		●				●	⊙							
- Metadata (for federation)	●	⊙																			⊙	⊙

● = Data Highly Applicable
 ⊙ = Data is Often or Partially Applicable
 □ = Data is Usually Not Applicable

Figure 17. Architecture Products and their Applicability

F. DODAF SUMMARY

Architecture is the “structure of components, their relationships, and the principles and guidelines governing their design and evolution over time.” An architecture description is a representation of a defined domain, as of a current or future point in time, in terms of its component parts, how those parts function, the rules and constraints under which those parts function, and how those parts relate to each other and to the environment.” To help ensure interoperable and cost effective military systems, the DoD has established DoDAF to describe DoD system architectures. The DoDAF is an evolution of the 1997 (C4ISR) Architecture Framework. The framework provides rules, guidance, and product descriptions for developing and presenting architecture descriptions. The DoDAF specifies three views that combine to describe the architecture. The three views are: Operational View (OV), Systems View (SV), and Technical Standards View (TV). Usually the OV of a system is doctrine-driven. The SV is used to

address specific systems. Architectures are developed for a variety of reasons. DoDAF users may develop Systems Views to describe the system's current state, to assist in transitioning to a new state, or to analyze future options. The DoDAF defines TV as the smallest set of rules overarching the interaction, interdependence, and arrangement of system parts or elements. The DoDAF also defines 29 architecture products, which are organized into All Views, OV, SV, and TV. It is intended to allow architecture descriptions of DoD systems to be related and compared throughout DoD, across service and even multi-national boundaries.

IV. ANALYSIS OF THE APPLICABILITY OF DODAF TO THE PACIFIC TRACKER CONVERSION

A. INTRODUCTION

In this chapter, the utility of applying DoDAF to the PT program is analyzed. An architecture for the PT is described, and the possible impact of the architecture on the course of the program is considered. The purpose of the PT is to fill radar gaps in a wide variety of MDA flight tests across the Pacific. The effort to convert a ship to host an instrumentation radar and telemetry system was conducted without the use of DoDAF. In this chapter, an architecture that could have been produced and utilized to support the conversion effort is described. The PT architecture consists of nine DoDAF data products. The data products are as follows: AV-1, OV-1-5, SV-1, 2, and 6. Each of these data products is subjectively assessed for possible impacts on the program's course.

B. SELECTED *BEAVER STATE* CONVERSION DODAF PRODUCTS

1. All View-1 Overview and Summary Information

AV-1 is a text document used to provide information: 1) to identify the project; 2) the scope of the architecture; 3) its purpose and viewpoint; 4) its context, and 5) the tools and file formats used. AV-1 for the conversion is provided as a PowerPoint slide in Figure 18.

AV-1 Overview and Summary Information

- **Architecture Project Identification**
 - Name: *Beaver State* conversion to *Pacific Tracker*
 - Architect: Mike Lash
 - Organization Developing the Architecture: MDA/DTR Sea Based Platforms
 - Approval Authority: TBD
 - Date Completed: Version 1.1 19 May 2009
 - Level of Effort and Projected Costs to Develop the Architecture: 200 hours
- **Scope: Architecture View(s) and Products Identification**
 - Views and Products Developed: AV 1; OV 1-5, SV 1-2, 6
 - Time Frames Addressed: Current and End State
 - Organizations Involved: MDA/DTR, MARAD HQ, MARAD Western Region, MIT/LL, WSMR, MDO, JHU/APL, Interocean American Shipping (IAS), NAVAIR, NSWC-Corona
- **Purpose and Viewpoint**
 - Purpose, Analysis, Questions to be Answered by analysis of the Architecture:
 - Assess whether incorporating DoDAF would have improved the way the project was done.
 - What DoDAF products might have been produced to support the project?
 - How may have the DoDAF methodology changed the way the project was done?
 - Would the DoDAF methodology have been useful to the project or be useful to future MDA test asset development projects?
 - From Whose Viewpoint the Architecture is Developed: Program Manager/ Systems Engineer
- **Context**
 - Mission: Conversion of *Beaver State* to Host XTR-1 and TTS-2
 - Doctrine, Goals, Vision: Produce a cost effective range instrumentation ship which will reduce BMDS dependence on land based radars
 - Rules, Criteria, and Conventions Followed: Must be compatible with other range assets
 - Tasking for Architecture Project and Linkages to Other Architectures: None
- **Tools and File Formats Used: Microsoft Office 2003**

Figure 18. Pacific Tracker Overview and Summary Information

2. OV-1 High Level Concept Description

OV-1 provides a graphical high level description of the concept. As shown in Figure 19, the Pacific Tracker is designed to: collect and record X & S band radar data and S band telemetry data on BMDS flight test events; send and receive data via SATCOM to and from other test participations; and to operate in the BOA. The graphic shows the XTR-1 antenna mounted behind the house and the twin TTS-2 antennas mounted in front of the house. The graphic depicts the two sensors collecting data on an interceptor and target missile. Also, as depicted other test participants may be other sea base systems, airborne sensors, and land-based systems.

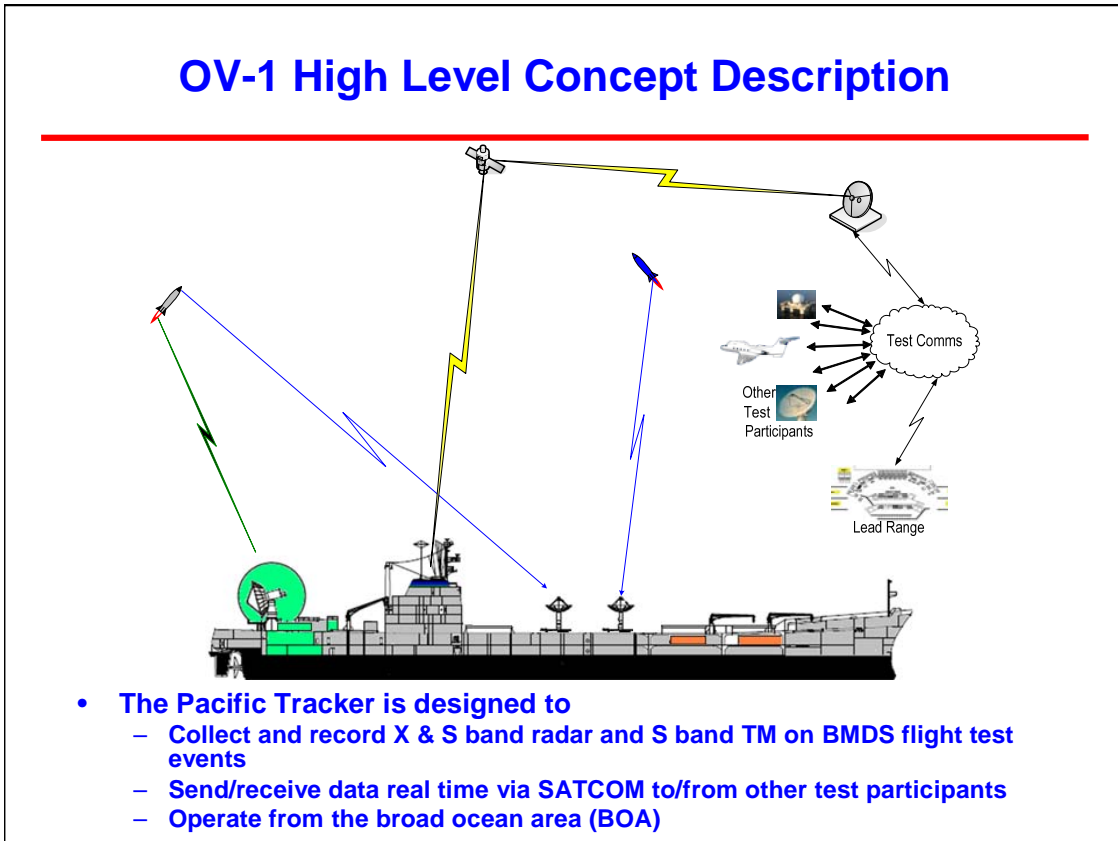

Figure 19. Pacific Tracker High Level Concept Description

3. OV-2 Operational Node Connectivity

OV-2, in Figure 20, provides a description of the operational node connectivity. A drawing of the physical system passing data to actors who are part of the test event is used. It seems that using such a drawing is a poor practice. The drawing can add to the confusion caused by having a physical system, the ship, the XTR-1, and TTS-2, called the Pacific Tracker; a project named Pacific Tracker; and a ship named *Pacific Tracker*. In the early phases of a test event, the physical system is not being used to exchange information with the Test Resource Manager (TRM). Test planners with the Pacific Tracker program will be exchanging information with the TRM by standard methods of business communications, for example, email and phone conversations.

The upper part of Figure 20 is taken from MDA Directive 3002.03 dated 15 January 2009. It shows the five phases of a BMDS test event: 1) Requirements, 2) Planning and Design, 3) Readiness, 4) Execution, and 5) Analysis and Reporting. In the first three phases and the first part of the fourth phase, the information flowing through the TRM to the Pacific Tracker program is data requirements, test event description, and status. Questions about capabilities and status will also flow to the PT program. Often, capability questions will start with “Can you...” or “What if...” The information that will be exchanged between the Pacific Tracker program and the test event via the TRM will tend to become more detailed as time progresses. The initial information will start with general information about data requirements and general information on the what, where, and when of the test scenario. As the level of detail of the data collection requirements and scenario information increases, so too will the level of detail in the plans the PT program provides back to the test event via the TRM. During the first three phases and the first part of the fourth phase, the PT system will not be used to support the test event.

OV-2 Operational Node Connectivity Description

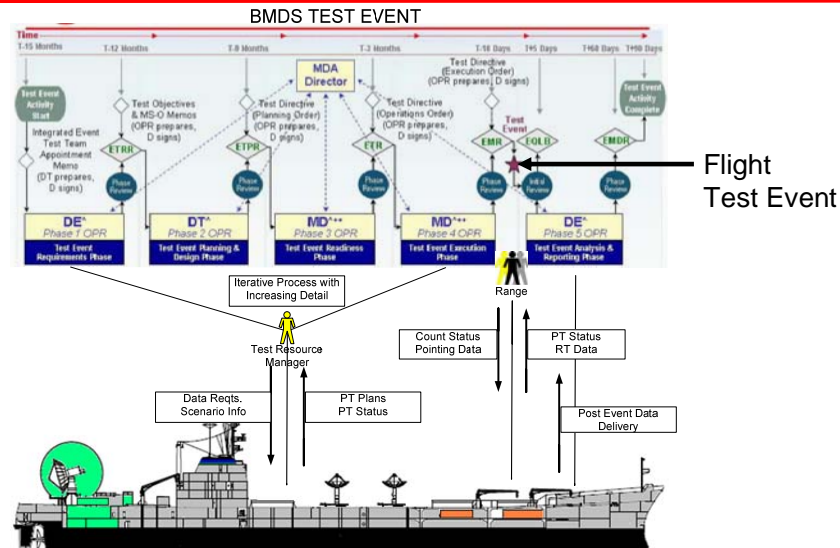

- **BMDS Test Events progress from start to completion through the five phases**
- **The PT program supports BMDS Test Event through all five phases**
- **The PT system supports the Execution phase**

Figure 20. OV-2 Operational Node Connectivity Description

For the design of the PT system, the node connectivity of the earlier phases is not as important as the node connectivity when the PT system is used. Current planning calls for the Pacific Tracker system to begin supporting a test event towards the later part of the fourth phase, Execution. A dockside communications demonstration is expected to be generally the first time the system will be used to support a given test. Then, sometime after the communications demonstration, the system will be put to sea. However, depending upon the distance between test support positions and the time between test events, the system may already be at sea during the first communications demonstration. The communications demonstration not only demonstrates that the communications links for the live flight test are operational; it also demonstrates the participant systems' ability to process simulated data.

The live flight test is depicted by the maroon star in Figure 20 labeled “Test Event.” For purposes of this thesis, the live flight test is the time that the missiles are in flight. During the live flight test, test data and voice communications will be exchanged between the test event via the range and the PT program using the PT system in real time. Figures 21 and 22 depict the node connectivity for test data and for voice communication, respectively. Figure 21 is the OV-2 that depicts the operational node connectivity for digital data passed between the electronic systems. Figure 22 is the OV-2 that depicts the operational node connectivity for voice communications.

Figure 21 shows connectivity between the range and the two sensors, XTR-1 and TTS-2. There is also connectivity between the sensors and the Pacific Tracker Lead (PTL) Situational Awareness Display (SAD). The type of information sent from the range to the sensors is the countdown clock and track data on selected test objects. Track data on the objects being tracked by the sensors are sent to each other and the range. Other selected data collected by the sensors are also sent to the range. The sensors will also send track data to the PTL SAD along with other real time data to keep the PTL advised of the sensors’ respective status.

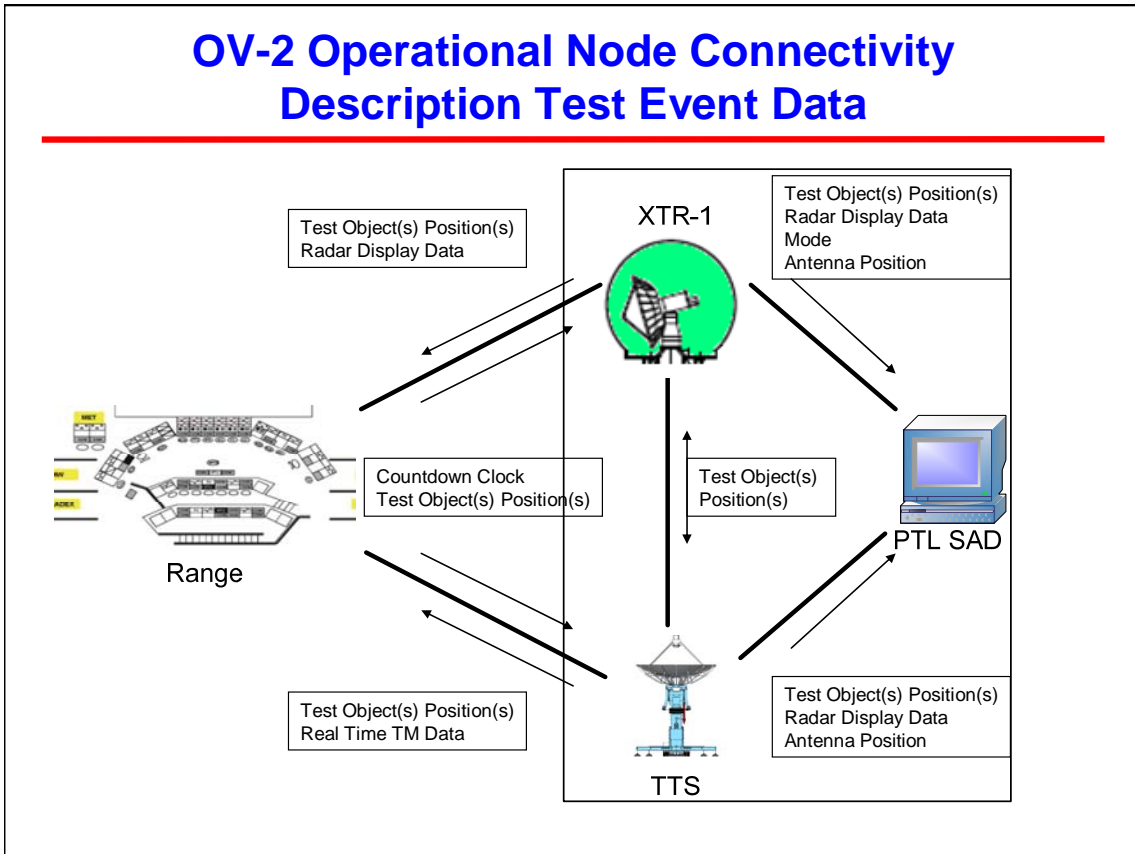

Figure 21. OV-2 Operational Node Connectivity Description Test Event Data

In addition to digital data passed between electronic systems, verbal communications will occur between individuals participating in the mission. Figure 22 is the OV-2 description for the verbal node connectivity during the test event. There will be other voice nets onboard and off board than what is shown in Figure 22. Figure 22 shows the primary voice nets. The intent is to have the PTL be the primary human interface with the range officer. One reason to do this is to reduce the task loading on the respective sensor leads. It is also intended that only one person, the PTL, is providing direction, requests, and questions to the ship's master.

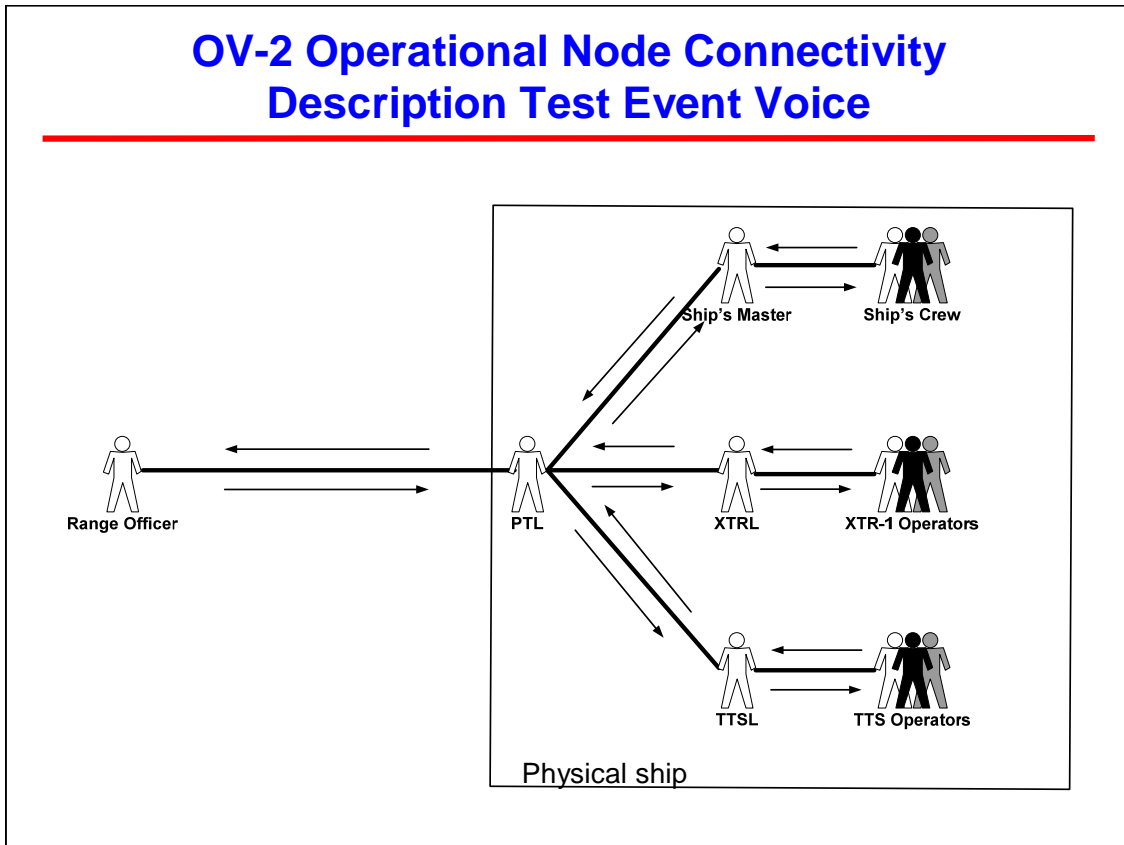

Figure 22. OV-2 Operational Node Connectivity Description Test Event Voice

4 OV-3 Operational Information Exchange Matrix

OV-3 is a tabular representation of operational information exchange along the need lines as depicted in OV-2. Figures 23 and 24 present more detailed listings of information exchanged between nodes and some information on what the receiving node does with the information. The format for Figures 23 and 24 was taken from Maj Hartt's executive seminar on DoDAF (n.d.). DoDAF 1.5 volume II provides an OV-3 template which allows for more details to be provided in the matrix. However, Maj Hartt's template addresses the key needs associated with the PT system (DoD Architecture Framework Executive Seminar, n.d.).

OV-3 Operational Information Exchange Matrix Test Event Data

Need Line	Information Exchange	Sending Node	Sending Activity	Receiving Node	Receiving Activity	Type
Range to PT	Countdown Clock	Range	Syncing Countdown activities to countdown clock	PT	Cueing for mission execution	Digital
Range to XTR-1 & TTS	Test Object(s) Position	Range	Processing position information from various sources and dissemination	XTR-1, TTS	Cueing for pointing antennas and setting range gate	Digital/ Interstate Range Vector
XTR-1 & TTS to range	Test Object(s) Position	XTR-1 & TTS	Processing position information from XTR-1 & TM and dissemination	Range	Processing position information from various sources and dissemination	Digital/ Interstate Range Vector
XTR-1 to PTL SAD	XTR-1 mode, antenna position, display data	XTR-1	XTR-1 operation	PTL SAD	Situational awareness	Digital
TTS to PTL SAD	TTS antenna position, TM data	TTS	TTS operation	PTL SAD	Situational awareness	Digital
XTR-1 to Range	Radar display data	XTR-1	XTR-1 operation	Range	Situational awareness	Digital
TTS to Range	Processed TM data	TTS	TTS operation and data processing	Range	Situational awareness	Digital

Figure 23. OV-3 Operational Information Exchange Matrix with Test Event Data

OV-3 Operational Information Exchange Matrix Test Event Voice

Need Line	Information Exchange	Sending Node	Sending Activity	Receiving Node	Receiving Activity	Type
PTL to RO	Tracker Status	PTL	Collect and disseminate Tracker (XTR-1, TTS, ship, and comm status)	RO	Collect and disseminate participant status	Voice, external range net
RO to PTL	Range Count	RO	Conduct Countdown	PTL	Execute mission plan or make adjustment accordingly	Voice, external range net
PTL to Ship's Master	Request Heading, Speed, Power Transfer, Status, Radiate	PTL	Execute mission plan or make adjustment	Ship's Master	Approve and implement or disapprove and explain	Voice, internal phone
Ship's Master to PTL	Acknowledge Heading, Speed, Power Transfer, SOLAS information	Ship's Master	Adjust heading and speed, coordinate power transfer, status and SOLAS	PTL	Inform TTSL & XRTL	Voice, internal phone
PTL to XRTL	Changes to Heading, Speed, Power	PTL	Disseminate changes to heading speed, power	XRTL	Respond accordingly	Voice, internal net
XRTL to PTL	Request Heading, Speed, Power Transfer	XRTL	Execute mission plan or make adjustment	PTL	Decide to relay to ship's master or not	Voice, internal net
PTL to TTSL	Changes to Heading, Speed, Power	PTL	Disseminate changes to heading speed, power	TTSL	Respond accordingly	Voice, internal net
TTSL to PTL	Request Heading, Speed	TTSL	Execute mission plan or make adjustment	PTL	Decide to relay to ship's master or not	Voice, internal net

Figure 24. OV-3 Operational Information Exchange Matrix with Test Event Voice

5 OV-4 Organizational Relationships

If DoDAF had been used, it is likely that the current and end state organizational relationships would have been considered. The organizational relations evolved over the course of the program. To keep the architecture description current, OV-4 may have been updated from time to time. Here, OV-4 is produced relative to two junctures in the program: the ASP and the shipyard contract award. Figure 25 shows the organizational relationships at the time of the ASP. Figure 26 shows the relationships at the time of the contract award. OV-4 descriptions are also produced for possible end state configurations. Figure 27 reflects possible overall program relationships, and Figure 28 shows possible relationships during flight test operations on the ship.

Figure 25 shows the relationships between the three branches, also called product offices, within the Test Resource Infrastructure Division (DTRI) involved with the Pacific Tracker program, Flight Safety and Telemetry, Sea-Based Platforms, and the Radar Development Branches. At the time of the ASP, the TM and Flight Safety branch had already developed TTS-1 & 2. This branch also oversaw the TTS-1 operations on the *Pacific Collector* and TTS-2 operations on land. The TTS was developed and operated by a group from WSMR. WSMR had selected NSWC-Corona to develop and operate its SATCOM system. The SBP Branch was charged with the responsibility to select and modify a ship to meet XTR-1 requirements. MARAD was the executing agent for SBS. MARAD Western Region, at the direction of MARAD HQ, engaged a firm, ICI and its sub contractor MDO, to perform the naval architecting. MIT/LL was still in the process of developing the XTR-1 for the RD Branch. The RD arranged for the targets group from NAVAIR, Naval Air Station, Pawtuxet River to be the EA for the radar operation through its contractor Computer Sciences Corporation (CSC). It was planned for CSC to provide the permanent crew for the XTR-1. The RD branch also went to NSWC Corona group to develop and operate the STACOM system. At the time of the ASP, the three branches were organizationally on the same hierarchical level; however, SBP was tasked to accommodate RD/XTR-1 requirements and soon after the ASP, TM&Safety/TTS requirements were added to the tasking.

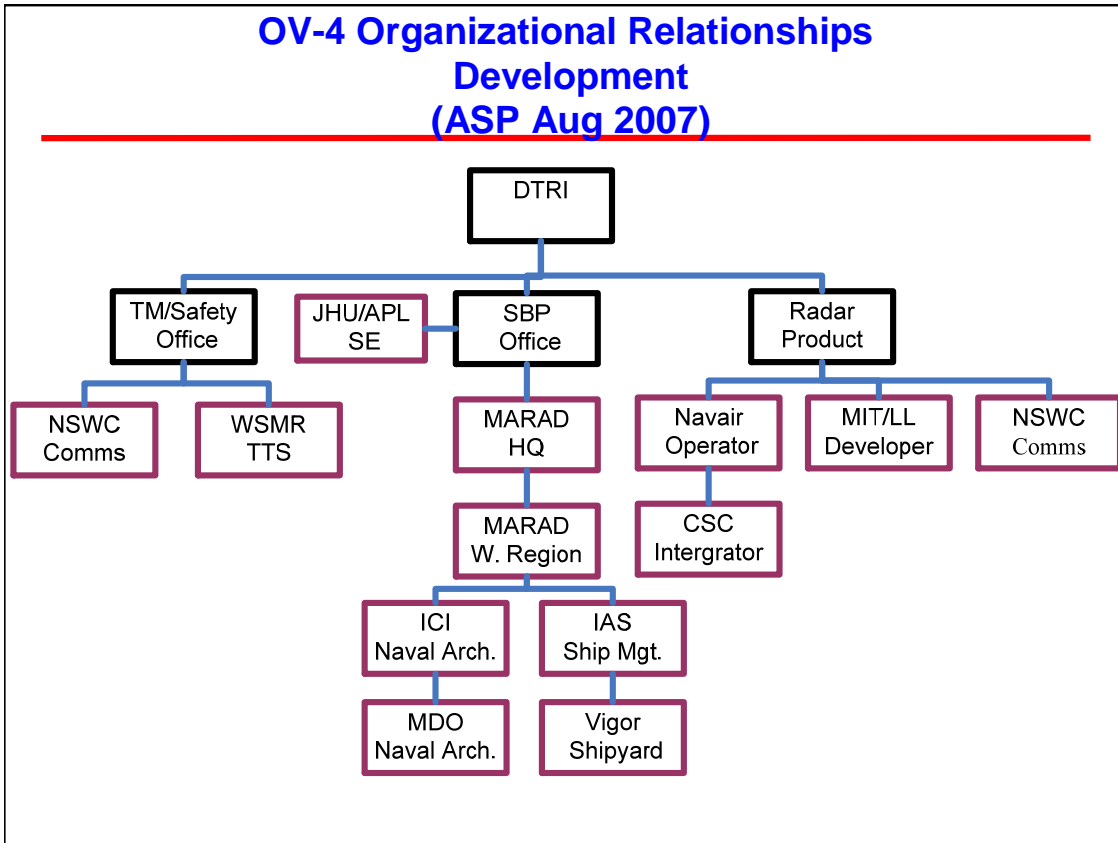

Figure 25. OV-4 Organizational Relationships August 2007

By the time of the shipyard contract award, the hierarchy among the DTRI branches had changed. Figure 26 reflects the organization at the time of the shipyard contract award. Most of the organizations were still involved; however, there were several significant changes. The TM/Safety Office was brought within SBP so that the vessels and on board instrumentation would have common management within DTRI. SBP also took over responsibility for the communications system and brought the Corona group within the SBP purview. MARAD was able to reduce one contract by moving the Naval Architects subcontract under IAS. By the time the contract was awarded, SBP was also assigned the lead systems engineering role for the Pacific Tracker program, a significantly different role than modifying a ship to meet XTR-1 requirements.

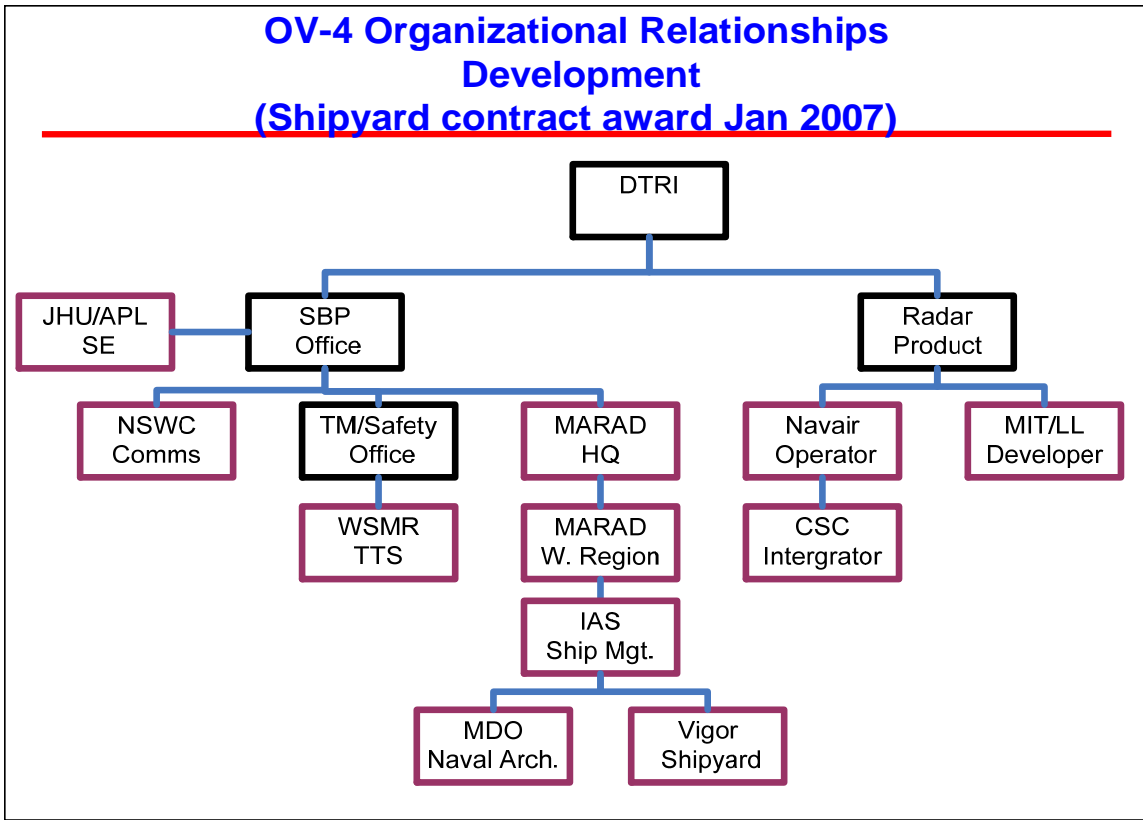

Figure 26. OV-4 Organizational Relationships January 2009

Once XTR-1 development is completed, current plans call for responsibility for XTR-1 to be brought within SBP, just as the TM/Safety Office was brought within SBP so that the vessels and on board instrumentation would have common management within DTRI. As shown in Figure 27, a possible end state is for the SBP office to be relative to only the Pacific Tracker program. Organizational relationships are not shown for the other systems: Pacific Collector, KMRSS/Worthy, and the MLP, within SBP. Figure 27 also shows how SBP will have to interface directly with at least five different organizations in order to manage the Pacific Tracker program.

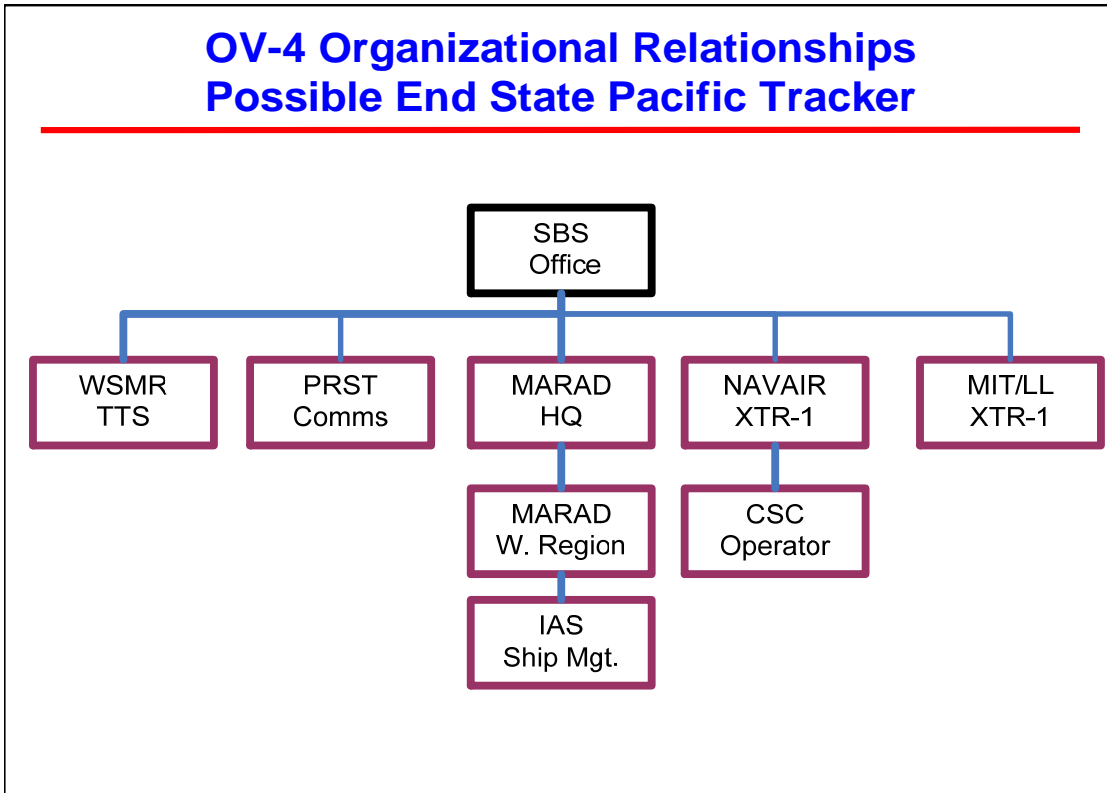

Figure 27. OV-4 Organizational Relationships, Possible End State Pacific Tracker

As part of the management of the Pacific Tracker program, the organization relationships onboard *Pacific Tracker* when at sea also needs to be considered. Figure 28 shows a possible configuration for the system at sea. While MARAD and NAVAIR will not disappear while *Pacific Tracker* is at sea, their roles will become more indirect, very much like SBP. It is not that the structure shown in Figure 27 goes away. It is that only a subset of the actors relative to the overall program goes to sea. The PTL will have more direct contact with the Range than she will have with the SBP. The thought behind Figure 28 is that the PTL will be responsible for top level direction and coordination of the XTRL, TTSL, communications, and the ship. To this end, the PTL is in the leadership position over the Pacific Tracker system and people deployed for the flight test. The ship's master is shown in a subordinate role to the PTL in relation to flight test support. The intent is to reflect the overall mission of flight test support. The master has supremacy in matters related to Safety of Life at Sea (SOLAS) and the safety of *Pacific Tracker*.

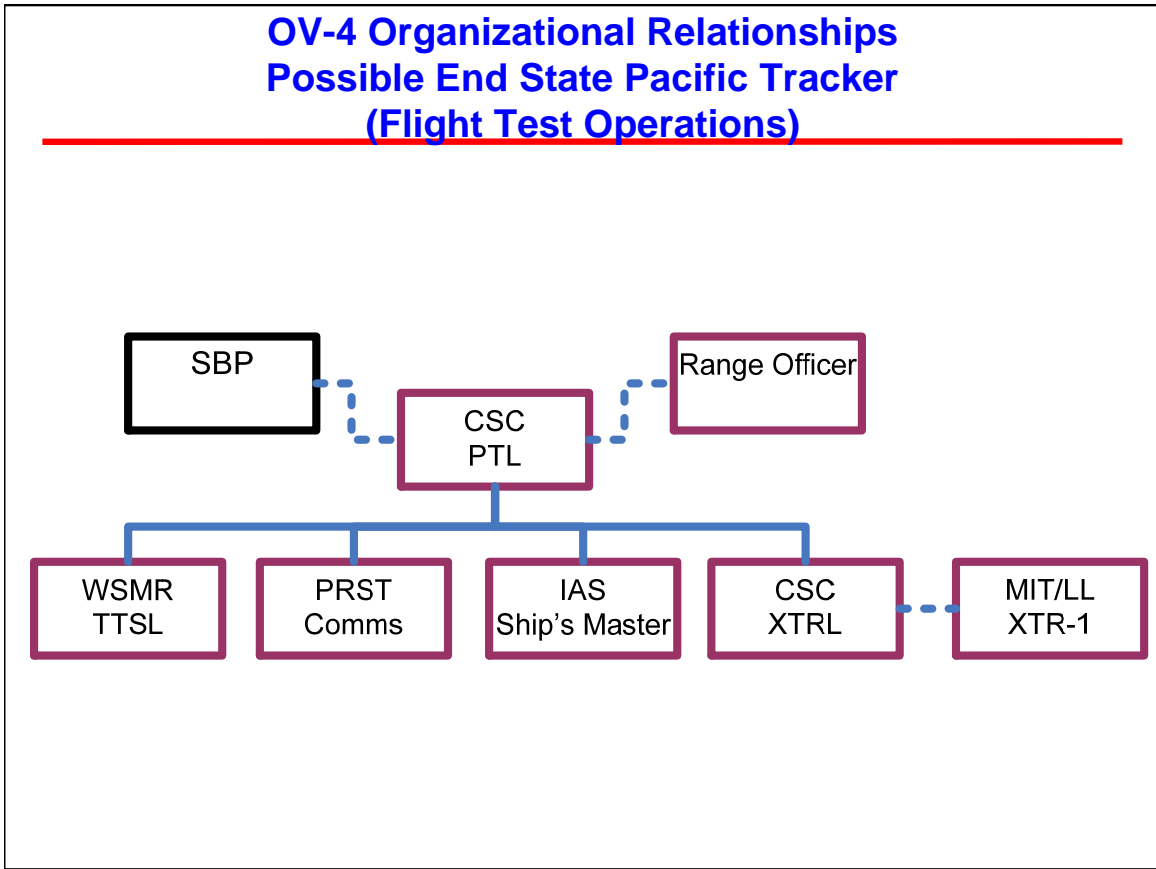

Figure 28. OV-4 Organizational Relationships, Possible End State Pacific Tracker (Flight Test Operations)

6 OV-5 Operational Activity Model

The next view is OV-5, Operational Activity Model. The model shown in Figure 29 closely matches the example in Maj Hartt’s DoDAF executive seminar presentation (n.d.). In his example, Maj Hartt was using an aerospace operations center (AOC) as an example. On first consideration, a missile range instrumentation ship does not resemble an AOC in form or function. However, in terms of the process, there is much overlap. Both the AOC and test assets can go through a planning – execution - maintenance cycle. The first step is to obtain information necessary for planning. Two general types of information entering the program are shown at the top left: Requirements and Test Event Information.

The requirements are listed first. The second type of information is test event related information. Requirements may be data collection requirements or regulatory requirements. Data collection requirements will, in part, describe what data will be collected on which test objects, for example. Regulatory requirements are laws, licenses, and restrictions applicable to any part of the Pacific Tracker operation. Test information is any information that may affect planning. Test information may or may not be directly related to the flight test. For example, information on launch windows is directly related to the test. Weather information, while not directly related to the test, can certainly affect data collection plans.

The BMDS test support planning group will take this information and produce a plan for the BMDS test execution group to utilize in order to conduct the mission. The planning group will also pass along other relevant information to the test support. The execution cell will support the test in accordance to the accepted plan. The execution group will provide reports and data outside of the PT. That group will also provide information to the maintenance group on the performance of the various systems. The maintenance group will provide information on the condition of the PT. This generic scenario can be applied to TTS, the radar, and even the ship. It has been my experience, depending on the level of specialization required, that the individual may find herself operating in one or more of the identified groups.

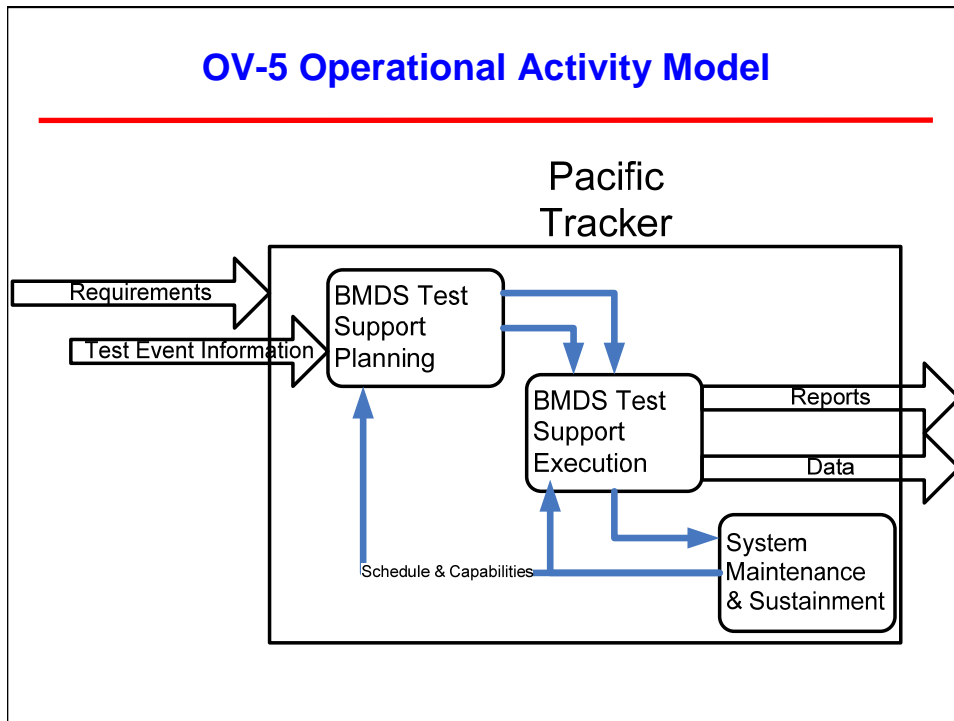

Figure 29. OV-5 Operational Activity Model

Another example of an operational activity model is shown. Figure 30 illustrates some of the activities associated with execution during the actual test event. The time period covered in this mode may range between 5 hours to 36 hours. The starting event is the start of the count and the receipt of the quick look report is used as the terminating event. The systems leads will ready their respective systems and provide reports to the PTL. The PTL will in turn provide these status reports to the range on a predetermined schedule that is usually called out in the script for the count down activities. Depending on the status of the various test participations, the range will have a decision to make on adjusting the count or proceeding as scheduled. The launch begins the data flow to the PT and other systems involved with the flight test. Pointing information in the form of inter range state vectors will flow to the radar and TM systems. The instrumentation leads with then attempt to establish track on their respective items of interest as established by the data collection plan. Once the systems are in track and collecting data, the systems will flow pointing information to each other and back to the range. The activity of collecting, recording, flowing data will continue until loss of signal (LOS).

After the data collection has ended, the execution team will produce a quick look, or multiple quick look reports. Reporting times can vary from program to program. The initial report, usually provided within an hour, is a qualitative assessment of how the system performed. Specific data products are requested to support the Quick Look Report, which is generally due within the first 24 to 48 hours.

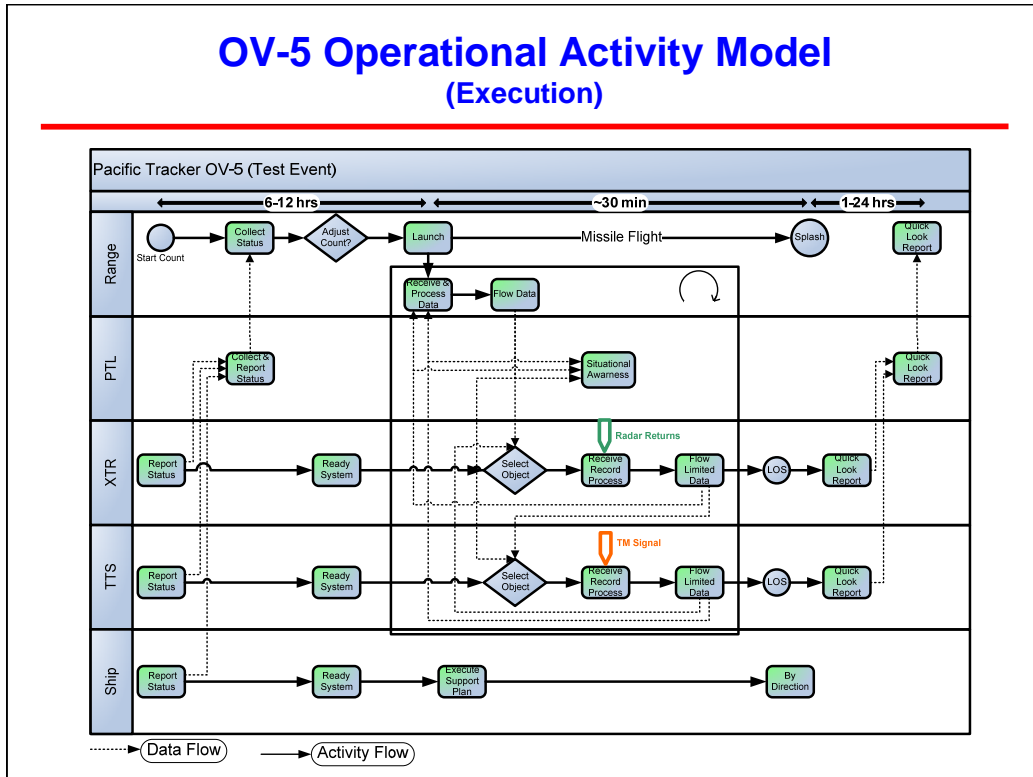

Figure 30. OV-5 Operational Activity during test execution

7 SV-1 System Interface Description

OV-2 provided a description of nodes or parts of the system that are connected to other parts of the system. SV-1 System Interface Description is found in Figure 31. It depicts two types of interfaces, voice and data. Voice interfaces are used between persons on *Pacific Tracker* and person(s) on the range. It also indicates data interfaces between systems on *Pacific Tracker* and the range. As shown in Figure 31, the XTRL, the TTSL, and the PTL will have voice communications amongst themselves and the range. In addition, the ship's master will have voice communications with the PTL. The

XTR-1, TTS, and the range will be connected in such a manner as to allow the transmission and receipt of data to and from each other. The PTL Situational Awareness display is able to receive data from XTR-1, TTS, and the range.

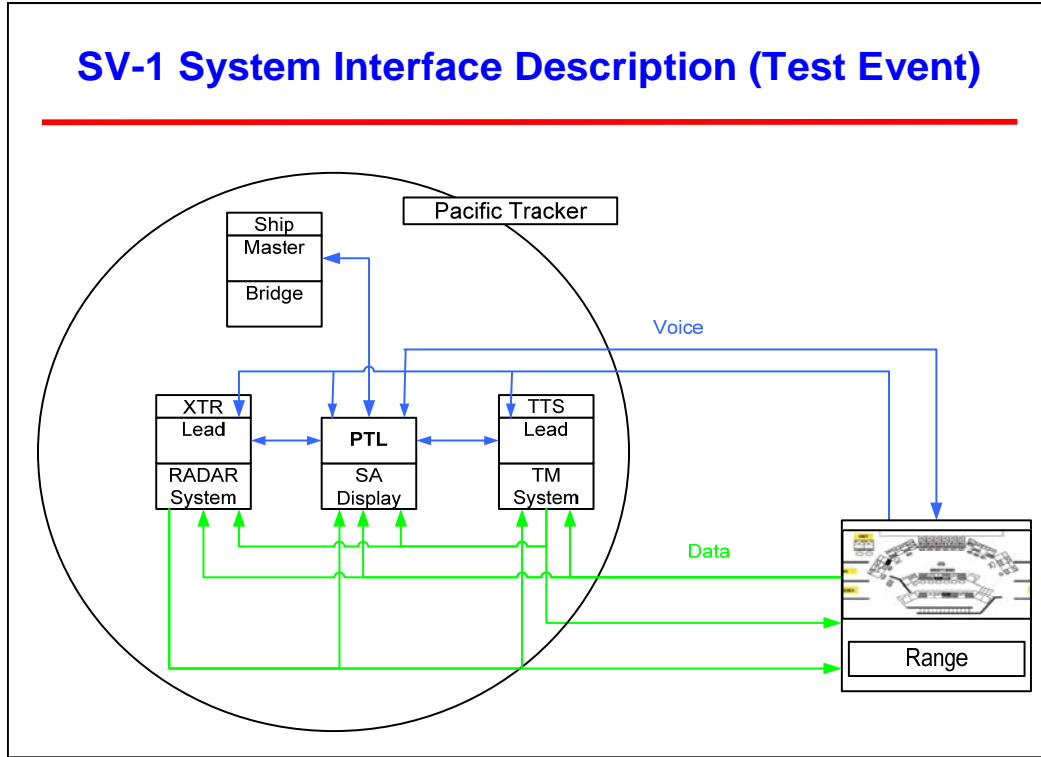

Figure 31. SV-1 System Interface Description

8. SV-2 Systems and Services Communications Description and SV-6 Systems Services Data Exchange Matrix

In Figure 32, SV-2, a different graphical depiction is used to provide more detailed information on the communications systems used to connect people and systems. Figure 32 in and of itself does not provide much additional data over what was depicted in SV-1, Figure 31. The SV-2 produced must be coupled with SV-6, Figure 33, to get more detailed information on the communications services. The SV-6 matrix contains information on the medium, bandwidth, and data format. Both of these products are capable of showing more information on the communications system than what is presented in this thesis. These products were intentionally left underdeveloped for reasons that will be discussed in the next section of this chapter.

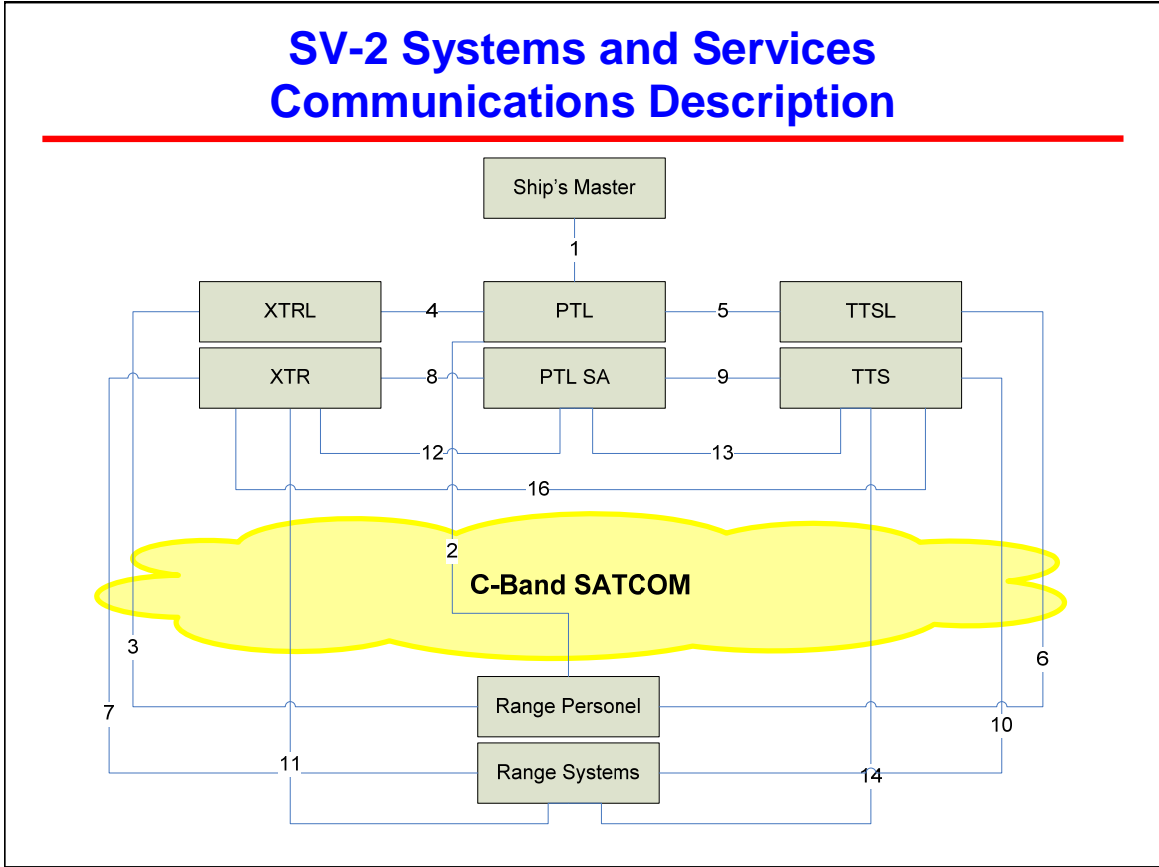

Figure 32. SV-2 Systems and Services Communications Description

SV-6 System Services Data Exchange Matrix

Sender	Receiver	Content	Media	Bandwidth	SV-2 Link
PTL	TTSL	Request Status	VOIP	L	5
PTL	Ship Master	Request Status	VOIP	L	1
PTL	RP	Provide Status	VOIP	L	2
PTL	XTRL	Request Status	VOIP	L	4
XTRL	PTL	Provide Status	VOIP	L	4
XTRL	RP	Provide Status	VOIP	L	3
XTR-1	RS	RADAR Data	IP Network	L	7
XTR-1	TTS	IRV	IP Network	L	16
XTR-1	PTL SA	IRV	IP Network	L	12
XTR-1	PTL SA	RADAR Data	IP Network	L	8
TTSL	PTL	Provide Status	VOIP	L	5
TTSL	RP	Provide Status	VOIP	L	6
TTS	RS	TM Data	IP Network	H	10
TTS	RS	IRV	IP Network	L	14
TTS	XTR-1	IRV	IP Network	L	16
TTS	PTL SA	IRV	IP Network	L	13
TTS	PTL SA	TM Data	IP Network	H	9
XTR-1	RS	IRV	IP Network	L	11
RP	PTL	Request Status	VOIP	L	2
RP	XTRL	Request Status	VOIP	L	3
RP	TTSL	Request Status	VOIP	L	6

Figure 33. SV-6 Services Exchange Matrix

C CONCLUSIONS: POSSIBLE IMPACT OF DODAF ON THE PACIFIC TRACKER PROGRAM

In my estimation, on the whole, had DoDAF been used, there might have been improvements to the program. However, these improvements would have been marginal. None would have significantly changed the course of the effort, though at times some of the products could have been useful. In particular, the operational views seemed to have the most potential utility. The system views appear as if they would have provided very little utility. If one considers the reasons for using DoDAF, one could have predicted its limited usefulness to the Pacific Tracker project.

Chapter II provided a description of some other ship systems used in missile defense testing and a description of the design evolution major modifications to the ship. The description of the other ship systems was provided in order to familiarize the reader

with existing systems or in other terms, familiarize the reader with what has been done before. The description of the evolution of four major elements, mission equipment electrical power, MDA mission personnel berthing, TTS antenna placement, and the communications system was provided to give the reader a sense of the major design issues confronting the conversion project. Three of the major design efforts, electrical power system, berthing, and placement of the TTS antennas with radomes have little or nothing to do with interoperability. Of the four major design efforts only the communications system is significant to interoperability.

According to the Defense Science Board, the major reasons for using a standardized architecture description, such as DoDAF, is to ensure interoperable and cost effective military systems (USD(A&T), ASD(C3I), J6, 1997). To paraphrase the DAU Glossary, interoperability for the Pacific Tracker system is its ability to provide data and information and accept the same from the Range and other test assets and to use the data and information to enable them to operate effectively together. The Pacific Tracker's communication system is an integral part of its interoperability. Since DoDAF grew out of the 1997 Command, Control, Communications, Computers, Intelligence, Surveillance, and Reconnaissance (C4ISR) Architecture Framework (DoDAF Version 1.5 v I), one might conclude that DoDAF would have been very useful. If this had been the first time a SATCOM system was developed to interface with a test range, the preceding conclusion would likely be valid. For the Pacific Tracker, it is not a valid conclusion because it has been done before. It has been done before on *Pacific Collector*, *KMRSS/Worthy*, and the MLP. While the communication system on *Pacific Tracker* is more complex than the other three, it is not much more complex. With the two sensors, it is more of a question of bandwidth than complexity.

In order for the Pacific Tracker system to be interoperable with the Ranges, the two sensors have to be interoperable with the Ranges as well as the communication system. Here again, it has been done before. The TTS-2 is already interoperable, it is an operating system. Its twin, TTS-1, is already operating on *Pacific Collector*. While the XTR-1 has yet to be fielded, it "...is based on the modern Radar Open Systems Architecture originally developed for the suite of instrumentation radars at the Reagan

Test Site” (MIT Annual Report 2008). Because the issues associated with interoperability have been previously resolved and the other major parts do not impact interoperability, the utility of DoDAF to the Pacific Tracker system was limited.

The utility of DoDAF seemed to be more associated with the operational views than the systems views. The organizational view, OV-4, and the process view, OV-5, proved to be the most interesting. They provided additional insight to the non-technical areas of the program. As this thesis defined the Pacific Tracker conversion effort, establishing processes for mission planning and pre-test event coordination are not part of the conversion effort. The design of the processes and organizations necessary for successful operation of the Pacific Tracker are candidates for further research.

THIS PAGE INTENTIONALLY LEFT BLANK

V. SOME IMPLICATIONS FOR OTHER MDA TEST ASSET DEVELOPMENT PROJECTS

The *Beaver State* conversion project has been successful without the use of DoDAF. This was due in large part to major interoperability issues having already been resolved. This may not always be the case. Other test asset development projects are likely to benefit as the complexity of the test asset interoperability issues. The other implication is the interoperability of organizations and processes associated with BMDS flight testing should also be considered.

The development of DoDAF products did not produce significant insights in regards to the four major elements, mission equipment electrical power, MDA mission personnel berthing, TTS antenna placement, and the communications system. However, the development of DoDAF products relative to organizations and processes related to the project did provide useful insights. The products OV-4 and OV-5, in particular, were useful. These products illustrated some complications with management of the project. While outside the scope of this thesis, an OV-5 depiction of the process which provides data collections requirements to the Pacific Tracker program, revealed several process ambiguities which may lead to confusion in the future.

THIS PAGE INTENTIONALLY LEFT BLANK

LIST OF REFERENCES

- ABS News room—Fact Sheet. (2005). American Bureau of Shipping. Retrieved January 3, 2009, from <http://www.eagle.org/news/newsroom-factsheet.html>
- Cobra Judy Radar System. (n.d.). Raytheon Company. Retrieved July 27, 2008 from http://www.raytheon.com/capabilities/products/cobra_judy
- Construction and Arrangement, 46 C.F.R. § 92 (2004).
- DoD Architecture Framework Executive Seminar. (n.d.). Maj Brian Hartt, Air Force Institute of Technology. Retrieved March 15, 2008 from www.afit.edu/ls/exec_seminarfiles/DODA_Exec_Seminar.ppt
- DoD Architecture Framework Version 1.0 Deskbook. (2003, August 15). DoD Architecture Framework Working Group. Retrieved March 26, 2008, from <https://acc.dau.mil/CommunityBrowser.aspx?id=31667&lang=en-US>
- DoD Architecture Framework Version 1.5, Volume I: Definitions and Guidelines. (2007, April 23). DoD Architecture Framework Working Group. Retrieved May 19, 2008, from http://www.defenselink.mil/cio-nii/docs/DoDAF_Volume_I.pdf
- DoD Architecture Framework Version 1.5, Volume II: Product Descriptions. (2007, April 23). DoD Architecture Framework Working Group. Retrieved April 3, 2008 from http://www.defenselink.mil/cio-nii/docs/DoDAF_Volume_II.pdf
- Fact sheet 08-FS-0012: Sea-based x-band radar. (2007). Missile Defense Agency. Retrieved July 7, 2008, from <http://www.mda.mil/mdalink/pdf/sbx.pdf>
- Glossary of Defense Acquisition Acronyms & Terms. 12th Edition, (2005, July). Fort Belvoir, Virginia: Defense Acquisition University Press. Retrieved April 12, 2008, from http://www.dau.mil/pubs/glossary/12th_Glossary_2005.pdf
- MDA Glossary, Version 4.0. (n.d.). Missile Defense Agency. Retrieved April 21, 2008, from <http://www.mda.mil/mdalink/pdf/glossary.pdf>
- Missile Range Instrumentation Ships - T-AGM. (2001, June). Military Sealift Command. Retrieved May 14, 2008, from <http://www.msc.navy.mil/factsheet/t-agm.htm>
- National Air Intelligence Center. (1998). Ballistic and Cruise Missile Threat (NAIC-1031-0985-98). Wright-Patterson AFB, OH: NAIC, Retrieved March 18, 2007 from <http://www.fas.org/irp/threat/missile/naic/index.html>
- News release 05-NEWS-0009: Missile defense radar exercise successfully completed. (2005). Missile Defense Agency. Retrieved January 31, 2009, from <http://www.mda.mil/mdalink/pdf05news0009.pdf>

- News release 07-NEWS-0028: Missile defense flight test successfully completed.. (2007, March 21). Missile Defense Agency. Retrieved January 31, 2009, from <http://www.mda.mil/mdalink/pdf/07news0028.pdf>
- News release 08-NEWS-0068: Successful sea-based missile defense intercept. (2008). Missile Defense Agency. Retrieved January 31, 2009, from <http://www.mda.mil/mdalink/pdf/08news0068.pdf>
- Range Safety. (n.d.) U.S. Army Space and Missile Defense Command. Retrieved July 27, 2008, from <http://www.smdc.army.mil/KWAJ/RangeSafety.html>
- Reagan Test Site. (n.d.) U.S. Army Space and Missile Defense Command. Retrieved January 31, 2009, from <http://www.smdc.army.mil/rts.html>
- T-AGS-29 Chauvenet. (n.g.) NavSource Naval History. Retrieved August 31, 2008, from <http://www.navsource.org/archives/09/10/1029.htm>
- Testing: Building Confidence. (2009). Missile Defense Agency. Retrieved April 4, 2009, from <http://www.mda.mil/mdalink/pdf/2009MDAbook.pdf>
- USNS Observation Island. (2001, July 30). Military Sealift Command. Retrieved October 5, 2008, from <http://www.msc.navy.mil/inventory/ships.asp?ship=133&type=MissileRangeInstrumentationShip>
- USNS Worthy: T-AGOS-14. (n.d.) NavSource Online. Retrieved April 5, 2009, from <http://www.navsource.org/archives/09/66/6614.htm>
- VT Halter Marine wins \$199M contract to build T-AGM(R) for the U.S. Navy. (2006, September 27). VT Halter Marine. Retrieved January 31, 2009, from http://www.vthaltermarine.com/press_releases/2006/20060927TAGMR.pdf
- Zheng, H. (2008, May 30). *Pacific Tracker External Communication Requirements*. Johns Hopkins University Applied Physics Laboratory. Laurel, MD.

INITIAL DISTRIBUTION LIST

1. Defense Technical Information Center
Ft. Belvoir, VA
2. Dudley Knox Library
Naval Postgraduate School
Monterey, CA
3. Steven Lopes
Missile Defense Agency
Arlington, VA
4. Iván Romero
U.S. Army Space and Missile Defense Command
Huntsville, AL
5. Loran Wingfield
Missile Defense Agency
Huntsville, AL