

NAVAL POSTGRADUATE SCHOOL
Monterey, California



THESIS

**THE USE OF POINT-TO-POINT LASERS FOR NAVAL
SHIPS**

by

Scott Bonk

June 2003

Thesis Advisor:
Co-Advisor:

Orin Marvel
Dan Boger

THIS PAGE INTENTIONALLY LEFT BLANK

REPORT DOCUMENTATION PAGE			Form Approved OMB No. 0704-0188
Public reporting burden for this collection of information is estimated to average 1 hour per response, including the time for reviewing instruction, searching existing data sources, gathering and maintaining the data needed, and completing and reviewing the collection of information. Send comments regarding this burden estimate or any other aspect of this collection of information, including suggestions for reducing this burden, to Washington headquarters Services, Directorate for Information Operations and Reports, 1215 Jefferson Davis Highway, Suite 1204, Arlington, VA 22202-4302, and to the Office of Management and Budget, Paperwork Reduction Project (0704-0188) Washington DC 20503.			
1. AGENCY USE ONLY (Leave blank)	2. REPORT DATE June 2003	3. REPORT TYPE AND DATES COVERED Master's Thesis	
4. TITLE AND SUBTITLE The Use of Point-to-Point Lasers for Navy Ships		5. FUNDING NUMBERS	
6. AUTHOR (S) Scott S. Bonk		8. PERFORMING ORGANIZATION REPORT NUMBER	
7. PERFORMING ORGANIZATION NAME(S) AND ADDRESS(ES) Naval Postgraduate School Monterey, CA 93943-5000		10. SPONSORING/MONITORING AGENCY REPORT NUMBER	
9. SPONSORING / MONITORING AGENCY NAME(S) AND ADDRESS(ES)		11. SUPPLEMENTARY NOTES The views expressed in this thesis are those of the author and do not reflect the official policy or position of the U.S. Department of Defense or the U.S. Government.	
12a. DISTRIBUTION / AVAILABILITY STATEMENT Approved for public release; distribution is unlimited		12b. DISTRIBUTION CODE	
13. ABSTRACT (maximum 200 words) <p>Currently the Navy uses microwave technology to wirelessly connect ships at sea. These systems provide approximately a 1.5Mb/s transfer rate and have some significant drawbacks. Microwave antennas provide a very large electromagnetic signature, require a large power source, and require a lot of support equipment and personnel to maintain connections.</p> <p>Laser technology can offer connection speeds 50 times greater than microwave, have no electromagnetic signature, use only a fraction of the space and power requirements, and require little to no personnel maintenance.</p> <p>Lasers offer many advantages to its microwave counterpart but it may also have some drawbacks. This paper addresses the effects inclement weather will have on range and bandwidth. Weather ranging from fog to heavy rain also is analyzed in relation to the current system.</p> <p>Aside from communications between ships, lasers offer other untouched tactical benefits including - enhanced communications between ships and remote controlled drones. Unmanned vehicles could provide full motion video, telemetry, atmospheric conditions, and provide an uplink for smaller water or land based terminals to the ship.</p>			
14. SUBJECT TERMS FSO, laser communication, Free Space Optics, networking, ship networks		15. NUMBER OF PAGES 100	
17. SECURITY CLASSIFICATION OF REPORT Unclassified		18. SECURITY CLASSIFICATION OF THIS PAGE Unclassified	19. SECURITY CLASSIFICATION OF ABSTRACT Unclassified
			20. LIMITATION OF ABSTRACT UL
			16. PRICE CODE

NSN 7540-01-280-5500

Standard Form 298 (Rev. 2-89)
Prescribed by ANSI Std. Z39-18

THIS PAGE INTENTIONALLY LEFT BLANK

Approved for public release; distribution is unlimited

THE USE OF POINT-TO-POINT LASERS FOR NAVY SHIPS

Scott S. Bonk
Ensign, United States Navy
B.S., Tulane University, 2002

Submitted in partial fulfillment of the
requirements for the degree of

MASTER OF SCIENCE IN SYSTEMS TECHNOLOGY

from the

NAVAL POSTGRADUATE SCHOOL
June 2003

Author: Scott S. Bonk

Approved by: Orin Marvel
Thesis Advisor

Dan C. Boger
Co-Advisor

Dan C. Boger
Chairman, Department of Information Sciences

THIS PAGE INTENTIONALLY LEFT BLANK

ABSTRACT

Currently the Navy uses microwave technology to wirelessly connect ships at sea. These systems provide approximately a 1.5Mb/s transfer rate and have some significant drawbacks. Microwave antennas provide a very large electromagnetic signature, require a large power source, and require a lot of support equipment and personnel to maintain connections.

Laser technology can offer connection speeds 50 times greater than microwave, have no electromagnetic signature, use only a fraction of the space and power requirements, and require little to no personnel maintenance.

Laser technology offers many advantages to its microwave counterpart but it may also have some drawbacks. This paper addresses the effects inclement weather will have on range and bandwidth. Weather, ranging from fog to heavy rain, also is analyzed in relation to the current system.

Aside from communications between ships, lasers offer other untapped tactical benefits, including enhanced communications between ships and remote controlled drones. Unmanned vehicles could provide full motion video, telemetry, monitoring of atmospheric conditions, and provide an uplink for smaller water or land-based terminals to the ship.

THIS PAGE INTENTIONALLY LEFT BLANK

TABLE OF CONTENTS

I.	INTRODUCTION	1
A.	A NEED FOR BANDWIDTH	1
B.	TRANSFORMATION	3
C.	COMMAND AND CONTROL	6
D.	INFORMATION SUPERIORITY	7
II.	TECHNICAL OVERVIEW OF LASER COMMUNICATION	13
A.	BRIEF HISTORY	13
B.	LASER TYPES	16
C.	USES	18
D.	LASERS FOR COMMUNICATION	19
E.	TRANSMITTER	22
F.	RECEIVER	24
G.	POINTING AND TRACKING SUBSYSTEM	33
H.	LIDAR (LIGHT DETECTION AND RANGING) TRACKING	36
I.	BURST-METHOD TRACKING	40
J.	LASERS IN THE ATMOSPHERE	42
K.	WEATHER	47
L.	BRINGING IT ALL TOGETHER	50
III.	CURRENT TECHNOLOGICAL DEVELOPMENTS	53
A.	FREE SPACE OPTICS	53
B.	PROJECT SALINAS	55
C.	NETWORKING REVIEW	57
D.	POSSIBILITIES	62
E.	INTEGRATED COMMAND ENVIRONMENT	68
F.	ADDITIONAL CAPABILITIES	72
IV.	SUMMARY	75
	LIST OF REFERENCES	77
	INITIAL DISTRIBUTION LIST	81

THIS PAGE INTENTIONALLY LEFT BLANK

LIST OF FIGURES

Figure 1. Virtual Organization [After Ref 3]	5
Figure 2. Laser Networked Ships	10
Figure 3. Ships Connected To Pier Network	11
Figure 4. Ruby Laser [After Ref 8]	15
Figure 5. Transmitter Block Diagram [After Ref 11]	23
Figure 6. Lase Output threshold [From Ref 11]	23
Figure 7. Laser Modulation [From Ref 11]	24
Figure 8. Laser Receiver [After Ref 12]	26
Figure 9. Photodiode Example [From Ref 12]	27
Figure 10. Pulse/Bit Recognition [From Ref 12]	31
Figure 11. Transfer Rate - BER to Power Output [From Ref 12] ..	32
Figure 12. Pointing and Tracking Subsystem [After Ref 10]	33
Figure 13. Quadrant Detector (QD) [After Ref 14]	37
Figure 14. QD Measurement Span [After Ref 14]	39
Figure 15. Burst Mode Block Diagram [After Ref 15]	40
Figure 16. Absorption of Water Vapor (top) and of CO ₂ (bottom) [From Ref16]	45
Figure 17. Absorption Curve with Aerosols [From Ref 16]	46
Figure 18. Point-To-Point Connection	58
Figure 19. Point-To-Point Between Networks	58
Figure 20. Ring Topology	59
Figure 21. Star Topology	60
Figure 22. Hub Architecture	60
Figure 23. Switch Architecture	61
Figure 24. Current Email Distribution Steps	64
Figure 25. Directly Connected Link	65
Figure 26. Advanced Routing Example	66

THIS PAGE INTENTIONALLY LEFT BLANK

LIST OF TABLES

Table 1.	Gas Lasers [Ref 9]	17
Table 2.	Liquid Lasers [Ref 9]	17
Table 3.	Solid-State Lasers [Ref 9]	17
Table 4.	Other Laser Types [Ref 9]	18
Table 5.	Early Laser Communication Issues [Ref 10]	20
Table 6.	Materials for IR Lasers	21
Table 7.	Photodetector Basic Functions [Ref 12]	25
Table 8.	Photodetector Types [Ref 12]	26
Table 9.	Photodiode Operation [Ref 12]	28
Table 10.	Photodiode Detector Specifications [Ref12]	29
Table 11.	Coarse Steering Gimbal Assembly [Ref 13]	34
Table 12.	Coarse and Fine Tracking Detector [Ref 13]	35
Table 13.	Quadrant Detector Beam Tracking Process [Ref 14] ..	38
Table 14.	Burst Mode Phase 1 [Ref 15]	41
Table 15.	Burst Mode Phase 2 [Ref 15]	42
Table 16.	Burst Mode Phase 3 [Ref 15]	42
Table 17.	Fog Effects [From Ref 16]	49
Table 18.	SALINAS and SATRN Opportunities [Ref 31]	56
Table 19.	Potential SALINAS/SATRAN Platforms [Ref 32]	56
Table 20.	Benefits Over Microwave [Ref 32]	56
Table 21.	SALINAS/SATRAN Single Channel Equivalence [Ref 32] ..	57
Table 22.	Integrated Command Environment Benefits [Ref 29] ..	71

THIS PAGE INTENTIONALLY LEFT BLANK

ACKNOWLEDGEMENTS

I would like to thank my wife and son for their love and support during this lengthy endeavor.

Special thanks to Dr. Orin Marvel for allowing me to follow up on an idea of his and for giving me the freedom to find my own way through it. I would also like to thank Dr. Dan Boger whose overwhelming patience for my apparent lack of narrative appeal and grammatical structure added greatly to the readability of this thesis.

THIS PAGE INTENTIONALLY LEFT BLANK

EXECUTIVE SUMMARY

Whether the reason is new asymmetric threats that are challenging our way of life or the basic need to be smarter, faster and more effective, Naval ships are becoming more dependent on flexible high-speed communications. In the fairly recent past, the military had very little access to smart weapons and highly flexible sensors. Today, we have the ability to place sensors in areas that were formally out of reach. The new breed of sensors are now riding on unmanned vehicles and are gathering gigabytes of data never thought possible. Likewise, smart weapons are now being used in conjunction with new sensor technology to put a weapon within a few feet of the target. This ability to apply surgical strikes saves the lives of our forces and that of the civilian population in the battle space. As this technology grows however, the narrowing gaps in our ability to see and shoot the enemy are being offset by the increasing difficulty our forces are having trying to transfer data from one platform to another. This paper hopes to provide such a solution.

Laser communication technology has come a considerable way in the course of its long history. Lasers are being used in ways considered purely science fiction just a few years ago. Today links providing gigabit speeds are being installed between buildings, satellites, and many other platforms. Ships are just one possible platform to house laser communication technology.

The following chapters in this paper provide the reader with some insight into why the Naval fleet desperately needs an upgrade to its current communications

infrastructure. It also looks at the history and other uses for laser technology with the hope of giving the reader a greater understanding of the breadth of effects that laser technology has on our modern world. Then the paper provides a systems level breakdown of the components and methods to creating laser-linked entities. Lastly, the reader is given some of the authors insight into a small portion of the potential laser networked ships could have on the modern battle space and conducting joint operations.

THIS PAGE INTENTIONALLY LEFT BLANK

I. INTRODUCTION

A Naval Fleet with ample bandwidth brings nearly limitless possibilities for commanders and sailors alike. Passing information back and forth in seamless transactions that are lightening fast and require about the same foresight as making a phone call are dreams of many in the Navy. From a technical point of view, bandwidth is a limited resource that needs to be guarded. It requires management and priority to ensure that a median level of network performance is always available. This paper hopes to address the ever-growing need for bandwidth and provide a possible solution.

A. A NEED FOR BANDWIDTH

Today's fleet is living in a world that is short on bandwidth and high on demand. Streaming video, PowerPoint presentations, email, and electronic files that are required to conduct business of the day can reduce throughput dramatically. For the fleet to continue to progress towards smarter, more connected ships with smaller manning requirements, the connection between each ship must be increased to deal with demand.

Stating that sea-going commands have a bandwidth crunch seems so obvious that one really should feel no need to say it out loud. But the reality is surface ships are finding it more difficult to use current communications methods with their existing network connections. On 31 January 2002 Wired News (publishers of Wired Magazine) posted a piece on the current state of the Navy's networking challenge. They articulated the difficulty that ships have sending files to each other. This difficulty becomes even greater when the ship is an older model, like a Frigate [Ref 1]. During an interview at a recent

conference, General Lance Lord, Commander, Air Force Space Command, was asked about current satellite bandwidth issues, "Bandwidth gets consumed. It is like software - applications grow until you fill up all the memory you've got" [Ref 1]. During his interview General Lord also joked, "Some say that 70 percent of that bandwidth was consumed by PowerPoint briefings." [Ref 1] This seems ridiculous but Captain Phil Wisecup, air wing commander on board USS John C. Stennis banned computer users from sending large files (including detailed PowerPoint presentations) over the network. He stated, "We made a specific decision to just go with black-and-white text. We're doing an important job, so lets keep it simple." [Ref 1] As stated before, PowerPoint presentations, email, and various communications are part of the Navy's network subsystem, only the administrative part, however.

If administrative operations can bring the network to a halt how can the fleet reasonably consider using a network for tactical purposes? General Lord, in the Wired article also mentioned that the current Afgan effort required almost ten times more bandwidth than the Gulf War. During the battle of Takur Ghar in Afghanistan, U.S. Special Forces were engaged in a mountaintop firefight. A Predator drone fed live video to commanders in Tampa, Florida. According to the Wall Street Journal, the military had to limit its use of Predators during operations. Only two of the six available were able to fly simply because there was not enough bandwidth to support them. [Ref 1] In the past naval operations were heavily dependent on manpower, logistics, and coordination. The future Navy is increasingly becoming dependent on bandwidth to the point where it is determining operational feasibility.

In order for the fleet to advance its technical potential and use the tools of the future, it will be necessary to have a large and reliable data pipe for each ship. The fleet will also have to create an entire new system for dealing with command and control and the process of using enhanced connections.

B. TRANSFORMATION

The fleet is moving towards a greater reliance on information. From the soldier in country to the commander INCONUS, the communication space between the warfighter and his/her leadership is becoming smaller and smaller. Likewise, the space between the roles of each branch of service is also becoming smaller and less defined. The Department of Defense has decided to call this change, Transformation, and it is intended to create a fleet/military that can deal with our perceived current and future threats.

Rear Admiral Jay Cohen during his February 2002 brief to the Armed Services committee explained Transformation as, "...changing the nature, function or condition..."[Ref 2] He went on to say, "That definition is a perfect description of the goal of Navy Transformation. You have challenged us, and we have challenged ourselves, to transform the Navy's ability to be even more responsive and more capable of meeting any current and future crisis."[Ref 2] Changing the nature, function or condition of the Navy gives some heading to the path the service is going to take. Fundamental in these changes, regardless of their intention, begins with communication. Without the ability to quickly move necessary data, efforts in planning are lost to physical distance and time constraints.

Transformation, in part, is an attempt to solve this communication problem. A subset of the transformation process

within human networking bounds is Network Centric Warfare (NCW). NCW stands as the theoretical basis for joint (including other services) information operations in the modern military. For this paper, *joint* is the connection between two entities that are coupled via some type communications network. An example would be two ships sharing some type of information-- voice, video, or data. Another example would be a UAV sending telemetry and video in real time to a ship. These devices will interact together in a way proportional to their ability to communicate. Basically, the faster and more convenient communications are the greater the abilities of the individuals. NCW will provide the framework to create these operations.

Two or more ships connected in a high-speed network using standard protocols have a tremendous amount of flexibility in their operations. Network Centric Warfare calls these potential connections Virtual Organizations. Imagine individuals and resources coming together to solve a problem that a single member could either not solve alone or would require more than the allotted time. Within a virtual organization, virtual collaboration tasks place. The participants of the group do not have to be in the same general location. Figure 1 is a graphical representation of this idea. A group of people specialized in the task at hand could work together until a project is complete and then could join or form other groups. Imagine a sailor that is attached to a Repair Division aboard a ship. He or she could have a problem trouble shooting some issues with a particular system. This sailor, under NCW, could consult technical representatives on board other ships or through a government contractor using the network. This would minimize repair time and allow highly experienced technical

representatives to share their knowledge with the war fighter in real time.

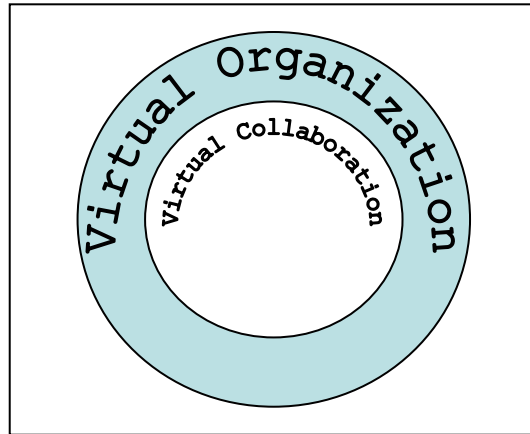

Figure 1. Virtual Organization [After Ref 3]

Providing additional information assets to sailors is one avenue to reduce crew size while maintaining access to highly skilled individuals. Time required to complete repairs could also be reduced. Direct access to additional resources outside of the ship becomes reasonable. Along with reducing the time to complete repairs, safety could also be increased. Sailors would be less likely to take the "Let's see what happens" approach to troubleshooting a particular problem. Procedures could be more closely monitored and the distance between the system designers and sailors could be reduced dramatically. Fielding systems could also happen quicker because technical representatives could be consulted without having to spend long periods of time on board ship.

The potential for change will also have a dramatic effect on the level and means of command and control. Like the sailor working at the ground level, a commander would be able to

initiate the same kind of connections in the command structure. New forms of streamlined command and control become available and allow for more quick and accurate decisions.

C. COMMAND AND CONTROL

Along with providing a framework for the virtual environment NCW provides new ways of dealing with command and control issues. Command and control, regardless of the level, is best when the commander is able to have an accurate picture of the situation. This awareness is enhanced when information is disseminated quickly to the appropriate people. On the naval battlefield, getting information from one entity to another can be a challenge.

NCW calls the time that it takes for a commander to recognize and understand a situation the Speed of Command. [Ref 3] Speed of Command is made up of command and control approach, organization, and systems. A group of ships that can effectively keep its team informed of the current situation increases overall awareness. In 1995 the People's Republic of China attempted to change the outcome of Taiwanese elections by using very visible saber-rattling (through a threat of invading). The U.S. response was to place two carrier battle groups in the Taiwan Straits. Admiral Clemens, commander of the Seventh Fleet, reduced the timelines for planning from days to hours.[Ref 3] He was able to use email, graphics, and video teleconferencing to create a detailed and high level of shared awareness among his ship commanders. This helped the two carrier battle groups to maintain synchronized operations and improve overall effectiveness.

The key effect here is the ability to communicate over various methods and maintain stable information flow. Increasing the overall potential for communications first requires

additional bandwidth. Admiral Clemins used the systems and connections that were available to him to increase the level of knowledge and do it in an efficient manner. Computer networks provided an efficient way to bring a large number of people together. Without this technology the Admiral would have had to bring a small number of senior personnel into a meeting room on a single ship and talk face to face. Those representatives would then have to take what they received from the brief and inform their subordinates. This would have limited the ability for questions to be raised and would open the plans for misinterpretation.

Admiral Clemins' access to high-speed communications of various types allowed him to keep two battle groups well informed and maintained a highly detailed assessment of the environment. Environmental clarity at the top level allows for more clear and detailed orders to be passed down. Subordinates with a clear understanding of their mission will perform better. This leads the organization closer to having a total grip on information.

D. INFORMATION SUPERIORITY

Under the Department of Defense's Joint Vision 2020 (JV2020), the services will move towards, "The ability to collect, process, and disseminate an uninterrupted flow of information while exploiting and/or denying an adversary's ability to do the same." [Ref 4] The key phrase in this statement is "uninterrupted flow of information". In order to create data flow models like the one described in the Joint Pub, the fleet must take a bottoms up approach to creating information centric workspaces. These spaces or divisions would then be grouped within a department and departments would be grouped into an overall ship group. For this to happen, the

number and types of access points available to systems, sailors, and commanders must be increased.

In order to have information available in real time, the Navy is reworking the way sailors and commanders stand watch and perform their respective jobs. Crewmembers will need to have access to many different types of network connections and services at the same physical location. One technology that is quickly moving into the forefront is wireless. The Navy's version of ship wireless has been dubbed Total Ship Monitoring. [Ref 5] This system will allow a crewmember to check on ship systems from anywhere on board. A captain would have access to real-time explanations of current ships speed, heading, and various other types of information. Likewise a sailor could view his or her systems status from any place on the ship. This would also allow for many types of triggers and alarms to go off when system parameters have gone beyond a prescribed level or are changing at an undesirable rate. This information could also be automatically logged in a ship database for training and evaluation purposes.

Currently the USS Howard is using wireless access points designed and built by the defense contractor 3E Technologies. Transmitters are being placed on pumps, and motors with software applications monitoring their state. [Ref 5] One effect of this technology allows smaller watch bills because it requires fewer sailors to monitor ship systems. Also, wireless saves money, space, weight, and design time because hundreds of feet of cabling will not need to be run to connect systems together. Eventually many of these systems could be monitored by computers which will use algorithms to determine what components need service and which need maintenance. [Ref 5]

Along with creating streamlined facilities management within a ship, system data tracking, managing, and monitoring from the battle group or higher could also be possible. If ships are designed to have full access to the internal and external environmental picture in real time, this data could also be shared to the next higher level. A battle group commander could have access to every ship in his group. He or she could see locations, speed, heading, and more with all of the data kept in real time and superimposed on a digital map or spreadsheet. This information could be obtained from something as simple as a webpage to a large screen view in CIC. The possibilities for a real time shared picture can only work if the Navy can provide enough access points and a large enough data pipe to handle the transmissions.

Laser communications are quickly becoming the preferred approach to linking computer networks together in areas where standard hard-wired lines are impractical or impossible. Networks linked with lasers have the ability to run at gigabit speeds and can be connected to almost any platform, including those that are moving relative to each other. The following chapters should provide the reader with an understanding of the history of laser communications, lasers in industry, laser system component design, and the possibilities they can create for the Navy of the future. Figure 2 shows three networked ships transiting out to sea. Figure 3 is an illustration of two ships tied to the pier and one pulling in; each ship has a laser link to the base network providing computer networking, Internet, and phones.



Figure 2. Laser Networked Ships



Figure 3. Ships Connected To Pier Network

THIS PAGE INTENTIONALLY LEFT BLANK

II. TECHNICAL OVERVIEW OF LASER COMMUNICATION

The following section is intended to give the reader some insight into the progression that laser technology has taken over the years. It also intends to show the reader the process and technology that drives current systems. Like many aspects of the technology sector, things evolve quickly; the systems and sub-systems described are intended to provide a basic understanding of the issues laser communications must deal with.

A. BRIEF HISTORY

A laser beam, or coherent radiation as scientists often call it, is a device that creates a highly directional, monochromatic beam of light with wavelengths that span from infrared to ultraviolet. A laser beam, unlike ordinary light rays, creates a beam that has little divergence. Laser beam divergence, even over great distances is small compared to an ordinary light source. Because lasers are highly focused and directed, they have many uses in the modern world. Their usefulness was not, however, readily apparent to the scientific community.

The laser era started in 1954 with the invention of the ammonia maser. This device showed that a focused beam could be created in the microwave region. One of the chief scientists on the project, Charles Townes, was teased by some of his colleagues over the amount of time spent and the cost of his project. His team had a government grant of \$30,000 and had spent the last two years working on the system. His team called their system a MASER (Microwave Amplification by Stimulated Emission of Radiation). Townes' peers, prior to the project's success, redefined the acronym as Means of Acquiring Support for

Expensive Research! Townes and his team would have the last laugh however, once the device was shown to be successful Townes and a few other scientists received the Nobel Prize for Microwave and Optical lasers. [Ref 6]

The invention of the ammonia maser in 1954 spurred intense competition for new sources of coherent radiation. The first real success was the ruby laser in 1960 by Harold Maiman. Maiman was the first person to make an operational laser. His system used ruby crystal surrounded by a helicoidal flash tube enclosed within a polished aluminum cylindrical cavity. Either end of the cavity was coated with evaporated silver to be internally reflective. One side of the cavity was only partially coated with silver so that some of the radiation escaped as a beam. His system operated in a pulsed mode rather than a steady beam because of the high pumping powers and heat dissipation requirements. [Ref 7]

A basic ruby laser (Figure 4) has a tube filled with ruby (CrAlO_3). The first step in the lasing process is to pump the material. Pumping means the lasing material is being excited at a molecular level. The ruby laser uses a flash tube (similar to a camera flash) to pump the material. Once the atoms in the material start to become excited the electrons in some atoms move two or three levels above the ground state. This increases an atom's degree of population inversion. Population inversion is the number of atoms in the excited state versus the number in ground state. At this point many of the atoms in the material are pumped. Some of these atoms will start to give up their excited state. When this happens, an electron returns to its ground state. Once the electron has returned to its ground state a photon is released. This photon moves from the atom at a

particular wavelength; additionally, it can come into contact with other excited atoms and cause them to release a photon. These photons begin to move throughout the tube and eventually reflect off the silver coating on either end. These photons will continue to reflect until they hit the area of the tube without the silver coating. These photons form the laser beam.[Ref 8] The ruby laser emits a red beam with a wavelength of 694nm. With a working laser system, scientists began focusing on other materials to lase and uses for those lasers.

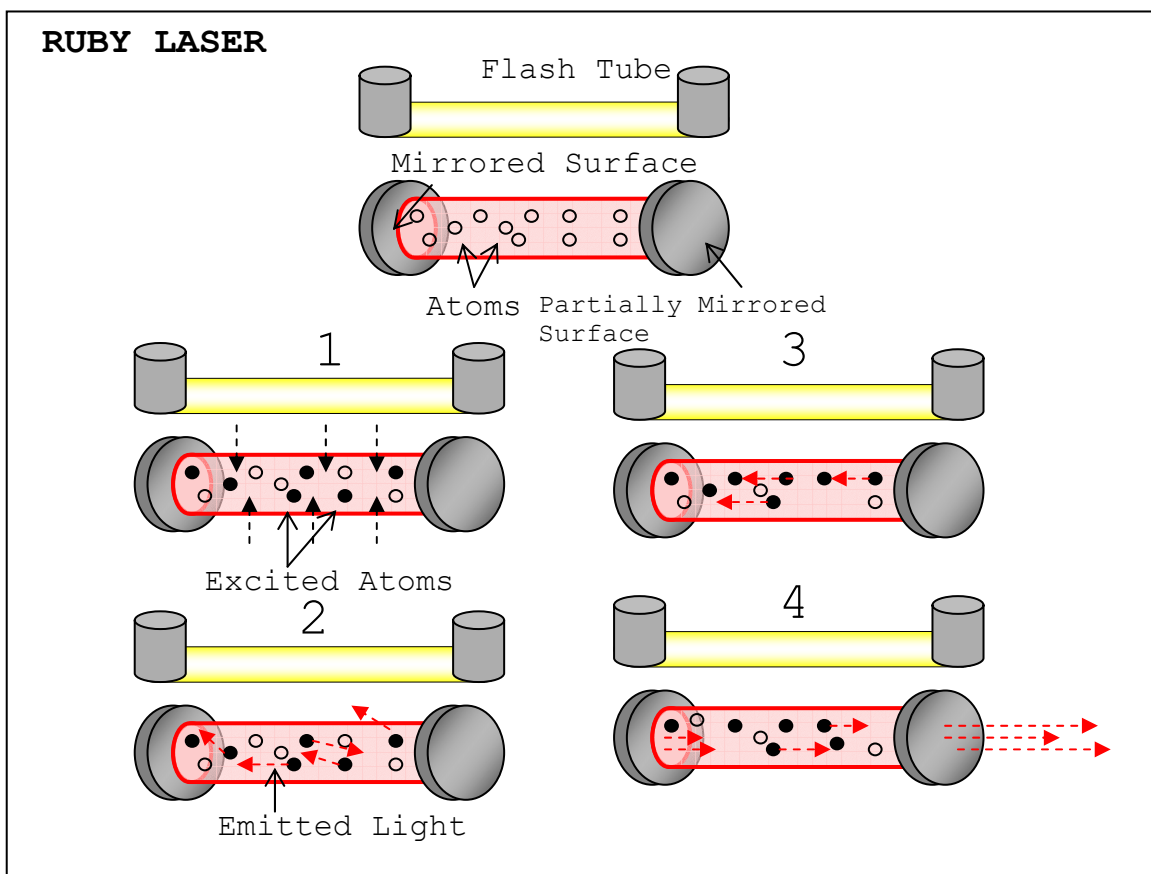

Figure 4. Ruby Laser [After Ref 8]

B. LASER TYPES

With the development of the ruby laser in the 1960's the scientific community saw a renewed interest in laser technology and different lasing materials. Researchers went off in many directions looking for different ways to create a laser beam. Today, there are thousands of different laser types at various levels of development. The major categories of lasers are gas, liquid, solid state, and plasma. Each of the various lasing materials produce beams with specific wavelength and strength. The diversity of lasers creates many different applications for laser technology. The following tables are examples of different types of lasers.

Neutral Atomic	Excited by weakly ionized dc- and RF-excited discharges, pulsed-afterglow discharges, and short-rise-time pulsed discharges (i.e., He-Ne laser)
Ionized Gas	Excited by large dc or rf discharge (i.e., argon ion, He-Cd, krypton).
Molecular	The CO ₂ laser is a good example. It can also be used to pump other molecular lasers, producing output further in the IR.
Chemical and Chemical Transfer Lasers	A system in which the lasing species is produced by the formation or breaking of chemical bonds on a reaction, regardless of how the reaction is initiated.
Excimer Lasers	Use heteronuclear and polyatomic excited molecules to produce UV light at high efficiency and peak powers.
Transfer Lasers	A compound (oxygen) is chemically excited to an excited level (the O-singlet Δ

	state) by a chemical reaction (usually involving hydrogen peroxide). The lifetime of the excited state (oxygen) is quite long, and it is collisionally mixed with another species (iodine) to form the laser excited state (COIL) concept).
--	---

Table 1. Gas Lasers [Ref 9]

Dye Lasers	One can get lasing by optically pumping a dilute solution or organic dye. The main advantage of dye lasers is that they can be tuned. Because dyes have fast relaxation times, they generally require very intense and rapid pumping—either by flashlamp or another laser.
------------	--

Table 2. Liquid Lasers [Ref 9]

Semiconductor	Generally lower power, highly divergent lasers operating at LN ₂ temperatures.
Color Center, or F-center	Low-power devices pumped by AR ⁺ or KR ⁺ lasers. These lasers use color centers in alkali halide crystals.
Insulating Crystal (such as Nd:YAG)	These lasers are usually flashlamp pumped. In addition to Nd, there are many other rare earth dopants to produce other laser wavelengths. As the cost of diode pumping approaches \$1-2/W, the technology will be utilized more extensively.

Table 3. Solid-State Lasers [Ref 9]

Free electron laser	
X-ray laser	
γ -ray laser	
"Jet flow" or "gas dynamic" laser	
Other lasers based on different storage and excitation techniques	Plasma excitation Exploding wires Shock waves Nuclear isomer energy storage

Table 4. Other Laser Types [Ref 9]

C. USES

With over forty years of development, the laser has proven to be an extremely effective tool in medicine, mechanical industry, telecommunication, space, and the military. Its applications range from life saving procedures, cutting steel, or transmitting data from place to place.

The medical profession has numerous uses for lasers. Certain beams are being used as a scalpel with great benefits. A cut from a laser causes the blood vessels to close quickly by coagulating the blood and lasers do not introduce bacteria into the wound. Surgeries that are performed this way often have patients recovering quicker with less pain, bleeding, and scarring. Lasers have also been used to destroy malignant cells (by heating them up) and joining two pieces of tissue together. Optometrist's are using lasers to permanently correct vision. Medicine, however, is not the only sector to benefit from lasers. [Ref 9]

The telecommunications community has benefited greatly from laser technology. Long haul fiber optic lines are used to carry laser beams for great distances. Laser/fiber optic communication also offers greater bandwidth than standard copper wire links (2-3 orders of magnitude). [Ref 9] This section would not be

complete with out mentioning laser communications (also called free-space optics). They are the next wave for low-cost extremely high data-rate communications.

The mechanical industry has found many uses for laser technology as well. Lasers are currently used by construction engineers to guide machinery and to accurately measure distances. High power lasers are also being used to precisely cut steel. Lasers are also being used in welding and drilling holes. Because they offer extremely small focal points and can be guided by machines, they are ideal for very precise highly detailed cuts and welds. [Ref 9]

The space sector has also found a number of applications for lasers. Satellites have been configured with laser radar that can measure distances in space and show how continents are shifting. Future satellite designs may offer inter-satellite communication using laser communications.

The military has also identified a number of useful applications for laser technology. A laser pointer can guide munitions carried from an airplane to a specific location on the ground. This dramatically improves the accuracy of the weapon and ensures that the intended target is the one that is hit. The services are also using lasers in measuring the distance to a target.

D. LASERS FOR COMMUNICATION

The use of light beams in the communication field at first thought might seem to be a fairly recent endeavor. The reality is light has been used for many years to communicate. In the past, two parties could use a heliograph to reflect sunlight and pass on some message. The heliograph became what we know today as the signaling mirror. After the invention of incandescent and

arc lights, ships at sea could relay messages back and forth. Later came modulated arc lights; they allowed voice communications links over 50 years ago. [Ref 10]

One of the first uses of laser communication through the atmosphere came from a Hughes group in November 1962. They used a 6328-Å Helium-Neon (He-Ne) laser to pass intelligible voice communication over a 30-Km link. Amplitude Modulation was used as a carrier. This extremely successful experiment showed that not only was a laser capable of handling communication but it was also able to provide it over long distances. [Ref 10] However, there were some hurdles still to overcome.

The use of lasers for long distance communication at the time was plagued with some obstacles. There were a number of problems the scientific community did not yet have solutions to. Table 5 illustrates the early technological and political problems system designers had various to overcome. [Ref 10] Even with all of these drawbacks the development of laser technology continued to progress.

1. Current telecommunications systems could handle demand.
2. There still was considerable research and development that remained to improve the technology.
3. A system in the atmosphere would always be subject to interruptions from rain, fog, and clouds.
4. Use of the system in space would require very accurate pointing and tracking devices. Pointing and tracking are complicated technologies in themselves and were not available at that time.

Table 5. Early Laser Communication Issues [Ref 10]

Because of the focus on hardwired systems and the technological difficulty of operating open-air lasers, many in the commercial communication sector looked away and pursued other applications. Even with this in mind there have been steady improvements in laser technology over the past 40 years.

Between 1965 and 1970 infrared became an important portion of the spectrum. Lasers capable of producing reliable IR beams were being designed and a number of materials were identified for this application. Table 6 details the materials discovered. Along with new materials to use, optical heterodyne technology (for signal detection) and pointing and tracking advances took place. [Ref 10]

Material	Wavelength
He-Ne	1.15 μm & 3.39 μm
Helium-Xenon	3.5 μm
Gallium Arsenide	0.9 μm
Nd:YAG	1.06 μm
CO ₂	6 μm , 10 μm

Table 6. Materials for IR Lasers

With the growing need for bandwidth in recent years expanding beyond the realm of copper wire connections, the communications community began anticipating future needs. Those needs would include high quality channels with large dynamic range and a high degree of linearity (i.e. cable TV). The possibilities that laser communication could provide created even more interest in the communications sector.

Today, there is a tremendous effort underway to provide high data rate communications to large buildings. Fiber optic, cable and DSL lines require considerable infrastructure to support and are not available in all areas. Point-to-point laser systems are starting to fill the gap. They are quick and easy to install, provide high data rates and offer the security of transferring company data directly to a neighboring building. This same technology could be the next step in Navy ship communications.

E. TRANSMITTER

By far the most fundamental unit of a laser communications system is the transmitter. It is the primary device that takes the modulated message and puts it in the air in the form of light. For laser communications systems, solid-state devices are normally used. It is for that reason this paper will look only at the main solid-state transmitter, the laser diode.

The laser diode, as previously mentioned, is a solid-state device that is used to create a laser beam. Figure 5 shows a basic block diagram of a laser diode. Its setup is very similar to the ruby laser in the previous section, however, the main difference is in the pumping technique. This device uses the properties of semi-conductor materials to excite the atoms in the material to generate population inversion and eventually begin the lasing process. Like in the ruby laser photons bounce back and forth in the resonant cavity until they pass through the semi-reflective portion of the mirror.

A laser diode is actually functionally similar to a light emitting diode. At low current levels a laser diode (LD) will actually perform as an LED. As the current applied to the LD rises it will begin producing a signal in the IR band. Once the

current (also called drive current) moves beyond the laser threshold current the material will begin lasing. Figure 6 shows the output as power is increased compared to an LED.

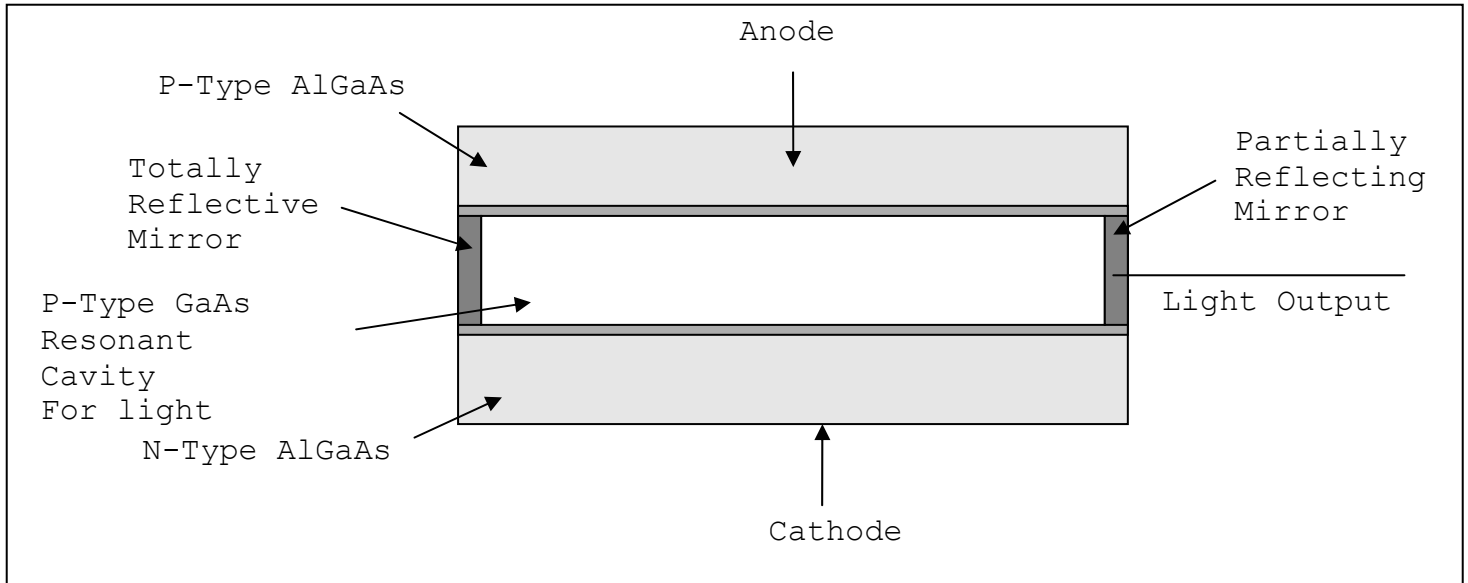

Figure 5. Transmitter Block Diagram [After Ref 11]

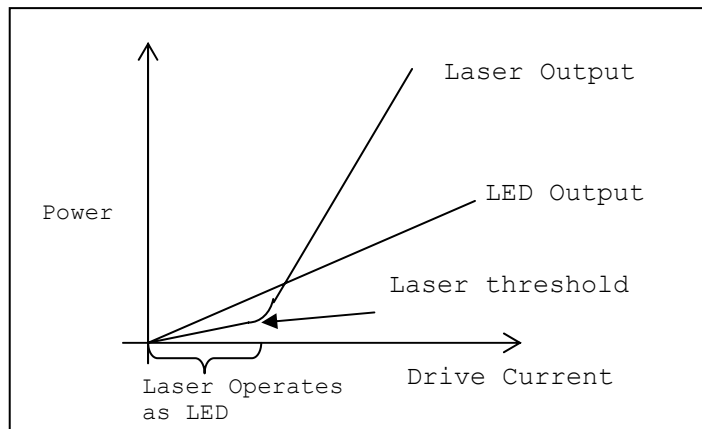

Figure 6. Lase Output threshold [From Ref 11]

The LD in a laser communications system needs to be able to output some form of modulated signal on the beam. LD's are capable of transmitting signals using analog and digital

modulation. By manipulating the current levels above and below the threshold level a digital modulated signal can be sent.

And under the same thinking an analog modulated signal can be sent by fluctuating the drive current in relation to the data signal. Figure 7 shows the various methods of modulation and provides a representation of modulation for placing digital intelligence on a laser beam.

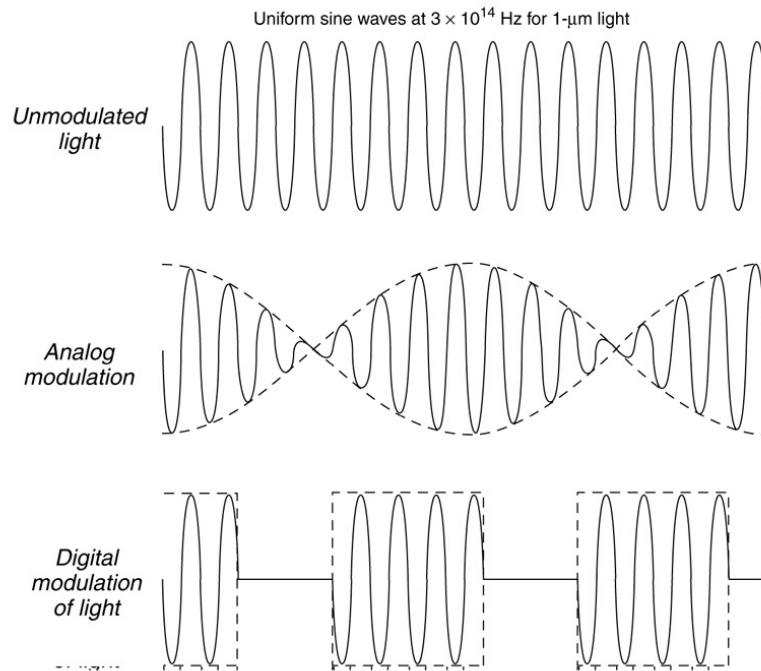

Figure 7. Laser Modulation [From Ref 11]

F. RECEIVER

The previous section gave an indication of the elements of a laser transmitter. This section provides some detail on the receiver of a laser communications system. In the simplest view, a laser receiver, called an electro-optical receiver, takes the transmitted beam and eventually converts it into an electrical voltage. These voltages are then, if the system is digital,

converted into bits that will be interpreted as the incoming intelligence from the transmitter.

Similar to other types of communications receivers, a laser receiver takes a received beam and converts it into usable electrical signals. Laser communications receivers use devices called photodetectors to perform the photon to electron conversion. Table 7 is a list of the three basic functions photodetectors perform. Figure 8 is a basic block diagram of the typical components required to make an electro-optic receiver.

Function	Sub function
Convert light into electrical current.	
Current is then amplified and converted to a voltage.	
Signal processing is applied as required.	Analog - Gain Noise filtering
	Digital - Thresholding - provides a clean rectangular pulse Adjustments to pulse timing (if required)

Table 7. Photodetector Basic Functions [Ref 12]

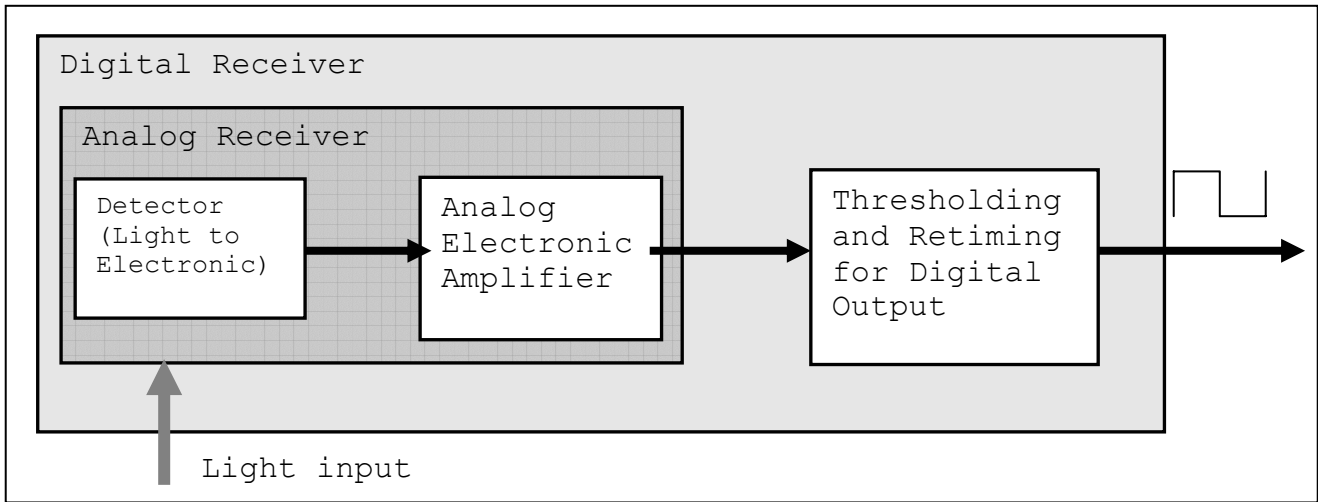

Figure 8. Laser Receiver [After Ref 12]

There are a wide variety of photodetectors available, however, for communications purposes; there are three primary types (Table 8).

Type
PN photodiodes
PIN diodes (p-intrinsic-n)
APD (avalanche photodiodes)

Table 8. Photodetector Types [Ref 12]

Each type of detector has particular characteristics that determine whether it is a good choice for a specific receiver design. PN photodiodes are a very low cost solution and provide relatively low performance. PIN diodes are slightly more expensive than a PN version, have a much better response, and are relatively easy to use. Finally, avalanche photodiodes (APD) are more sensitive than the previous two but are tricky to bias and can have response times that are slower than PINs. With a

basic explanation of the solid-state types, table 9 is a basic description of photodiode operation.

Figure 9 is an example of a photodiode and its method of operation. The PN, PIN, and APD diodes use similar functional parts as shown in Figure 9 but operate in different ways. Whatever type diode a system uses, the characteristics of that diode must be understood in order for the system to work efficiently. Table 9 is an explanation of the operation of a photodiode.

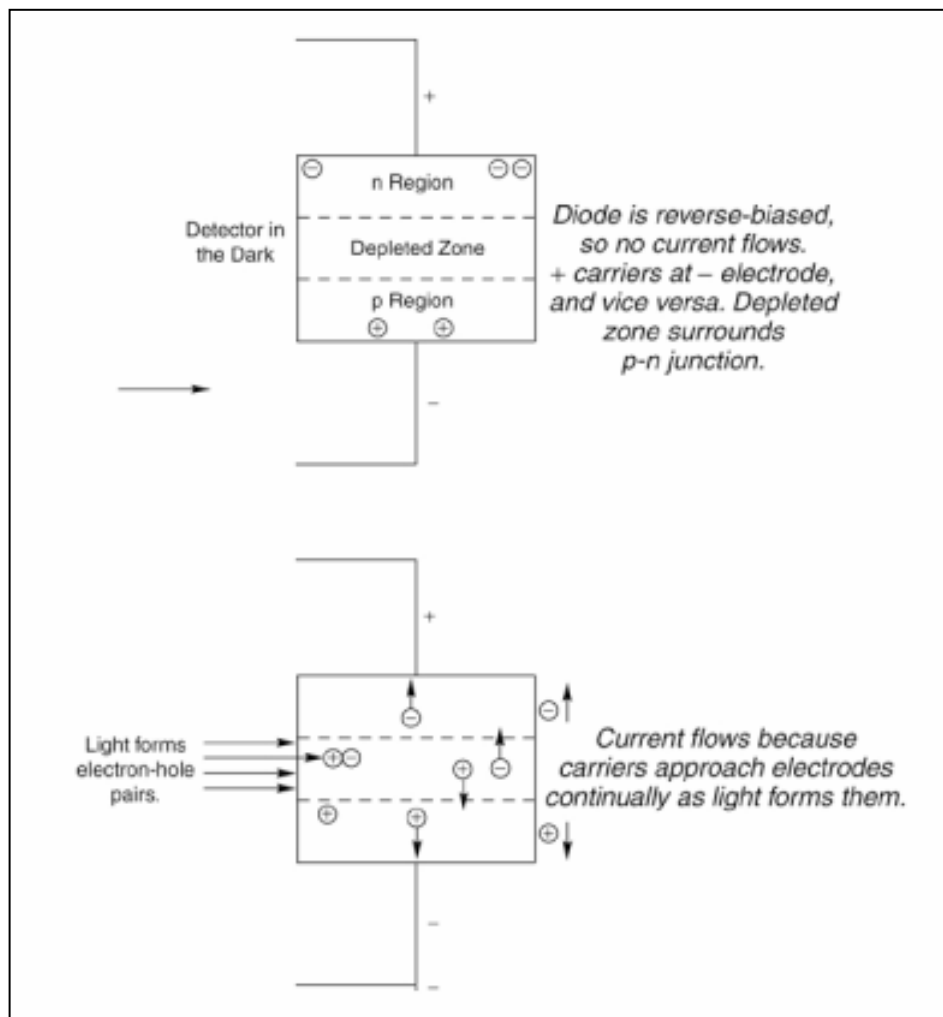

Figure 9. Photodiode Example [From Ref 12]

Photodiode Operation
1. Diode is reverse biased
2. Light photons create electron-hole pairs in the depletion region (or intrinsic region for PIN type)
3. Charge carriers form a current whose magnitude is proportional to the light intensity
4. Diode responds best to wavelengths close to the bandgap between valence and conduction bands

Table 9. Photodiode Operation [Ref 12]

Photodiodes have some important characteristics that are used to determine whether they are a good choice for receiver design. Table 10 is a list of the detector specifications for typical photodiodes.

Specification	Detail
Responsivity	Output current given light level - Units are A/W (or $\mu\text{A}/\mu\text{W}$)
	Specified at a particular wavelength
Quantum Efficiency	Electrons emitted per photon - < 1 for PIN type detector >> 1 for APD type detector
Dark Current	Output with no light coming in, this represents the noise level due to thermally generated free electrons
Noise Equivalent Power	Noise power equivalent to the dark current
Linearity (Dynamic Range)	The range over which current is proportional to light
Sensitivity	Power desired for satisfactory operation - For analog signals: signal-to-noise ratio (S/N) For digital signals: bit-error rate (BER)
Rise Time	The measure of receiver/detector speed - Defined as the time taken for the output to rise from 10% to 90% of maximum

Table 10. Photodiode Detector Specifications [Ref12]

Each of the characteristics for photodiodes has a detailed discussion that breaks down the technology. For this paper the reader is only introduced to the topic of photodiode technology; this paper can be used as a launching point for

further study. With that in mind there is one area that does have particular importance in digital communications and does deserve some amplification.

Bit-error rate (BER) is an important aspect in digital communication regardless of the medium. When using laser technology to deliver a digital message it is important to know the probability of bit error for the system being used. By definition BER is the proportion of bits that are received incorrectly. Normally bit error rates are extremely small numbers and are expressed in the form of 1×10^{-n} . An example BER would be 1×10^{-6} ; this tells the reader that a particular system will have one incorrect bit for every million bits transmitted. Figure 10 shows how bits can be received and how issues regarding amplitude and timing effect bit recognition. Figure 11 illustrates how incoming signal power affects BER for individual transfer rates.

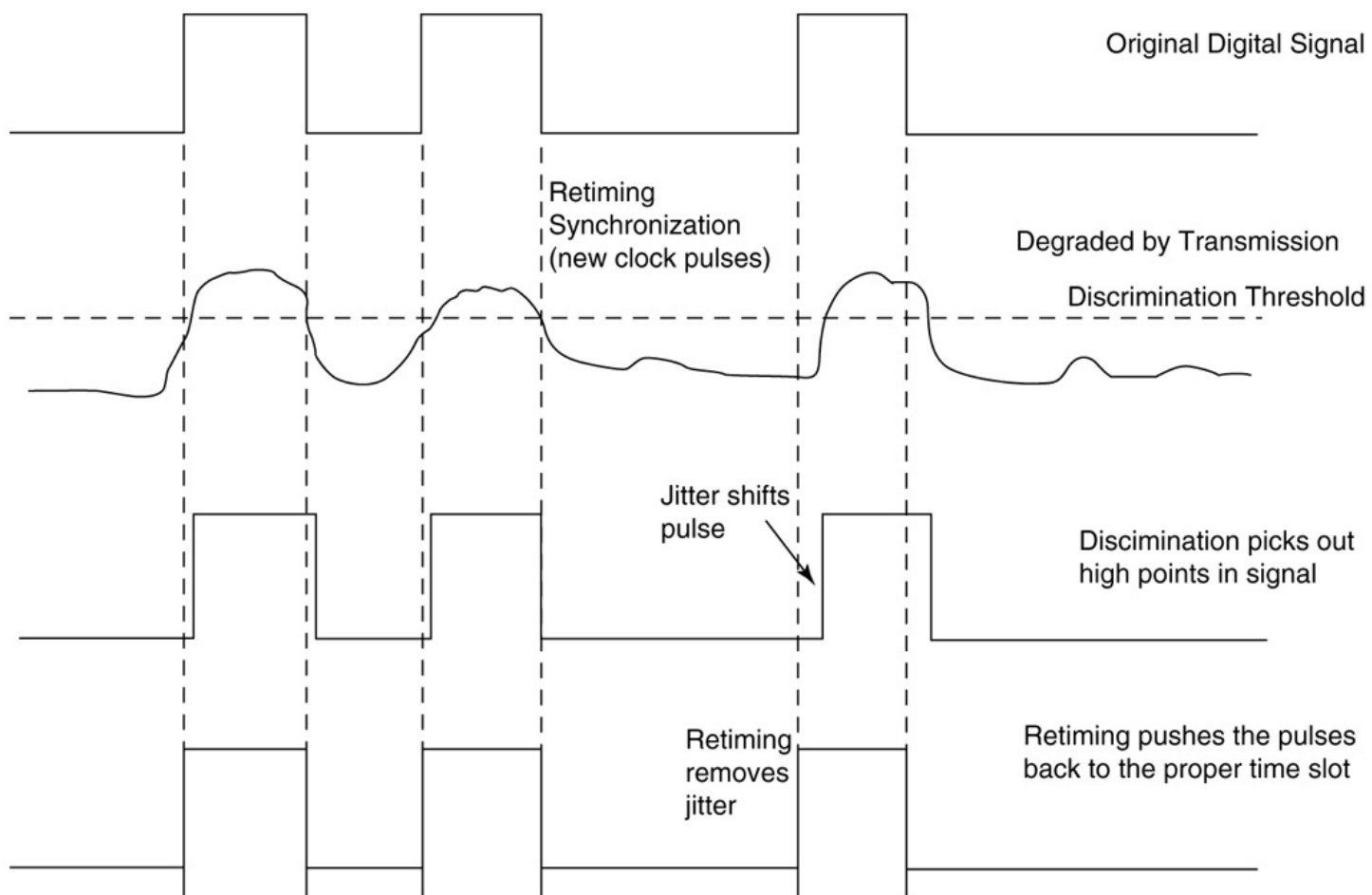

Figure 10. Pulse/Bit Recognition [From Ref 12]

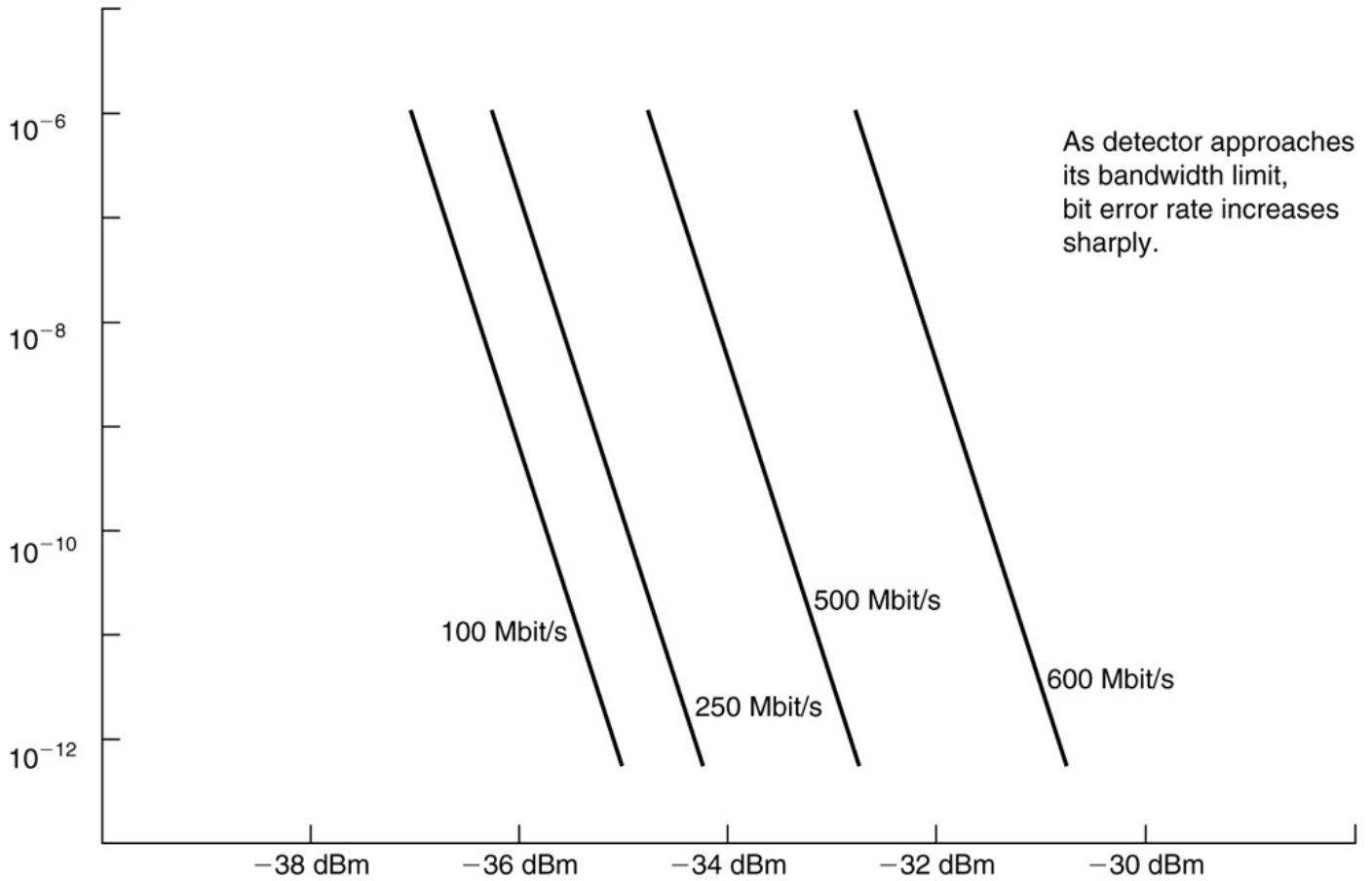

Figure 11. Transfer Rate - BER to Power Output [From Ref 12]

G. POINTING AND TRACKING SUBSYSTEM

At the heart of laser communications systems where one or both communicating nodes are moving, a system of tracking and pointing the beam is critical to maintaining a link. Figure 12 is a basic block diagram for a laser system to perform this very need. The diagram is not necessarily consistent with all laser systems, however, it is intended to illustrate the separate functions that must be dealt with.

When reading this section try to imagine the laser system riding on a stable platform. As the ship moves, the gimbal system allows the laser to remain fixed to a point in space. Ship movement can be anywhere in three-dimensional space. The gimbal system will help limit laser jitter, provide additional tracking and pointing due to ship movement and sea state. The gimbal system provides a virtual fixed platform for the laser to reside.

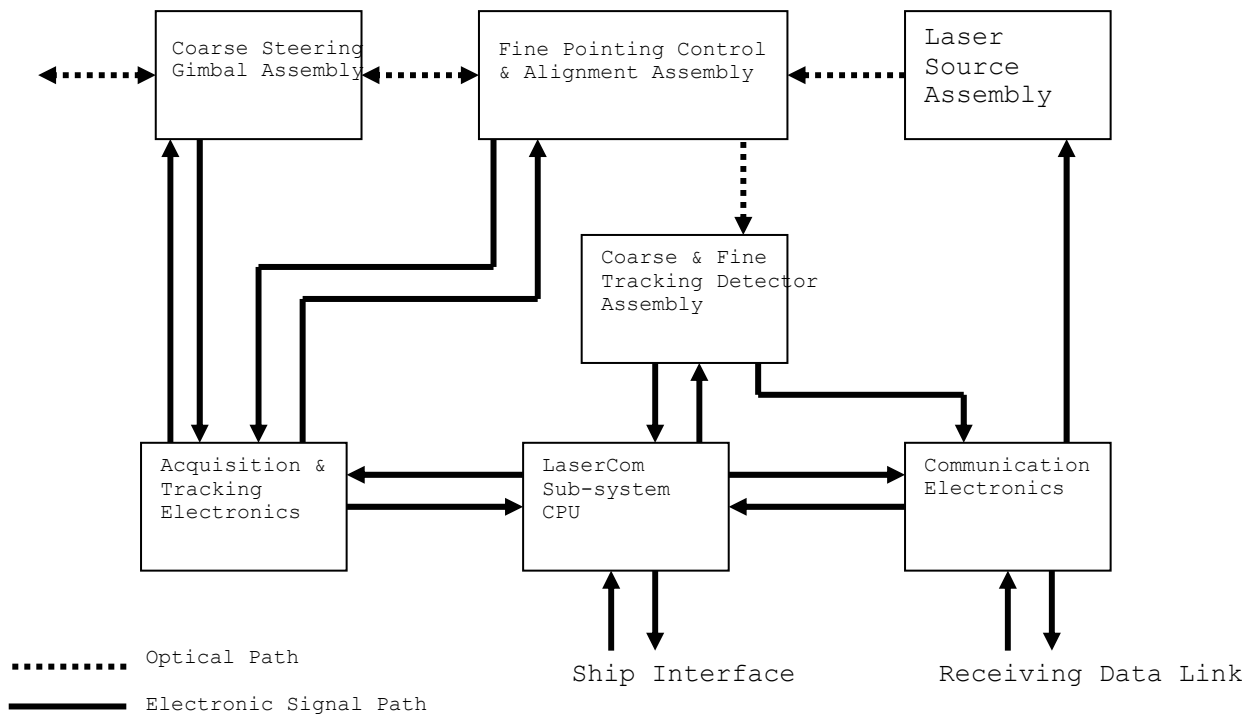

Figure 12. Pointing and Tracking Subsystem [After Ref 10]

Coarse Steering Gimbal Assembly: [Ref 13]

Table 11 illustrates the components of this assembly. During acquisition, this subsystem receives open loop gimbal angle and rate command signals from the acquisition and tracking electronics to steer the received broad acquisition beam laser into the acquisition detector's field of view (fov). During fine tracking this assembly monitors the laser beam and ensures that it is within fine tracking and pointing control subsystem dynamic range.

Components	
1.	2 or 3 axis gimbaleed telescope or flat mirror
2.	Relay optics assembly
3.	Gimbal angle pickoff sensing devices
4.	Gimbal servo drive motor

Table 11. Coarse Steering Gimbal Assembly [Ref 13]

Fine Pointing Control and Alignment Assembly: [Ref 13]

This portion of the system handles fine pointing control and alignment and is the primary laser comm. pointing assembly for the laser system. The system consists of several gimbaleed optics and various torque motors to perform fine pointing, look ahead compensation, and boresight alignment functions.

Coarse and Fine Tracking Detector: [Ref 13]

Table 12 is a list of the system components for this assembly.

Component	Sub Components
Two detectors - which can be quadrant detectors	Coarse detector - has a wider FOV Fine detector - has a more narrow FOV
Processor and various electronics	handle processing and routing of signals

Table 12. Coarse and Fine Tracking Detector [Ref 13]

Acquisition and Tracking Electronics Assembly: [Ref 13]

The purpose of this system is to perform laser signal acquisition, reacquisition, and track and point functions. This subsystem receives information from the central processing unit and the coarse and fine detectors.

Laser communication Subsystem: [Ref 13]

This system interfaces between the host vehicle and the laser comm. system for control and communication functions. Basically it accepts and processes commands from the ship.

Communications Electronics and Laser Source Assembly: [Ref 13]

The communications electronics handle the data coming in and out of the ship. This is the actual data transmitted and received that is sent to the ship's network.

The laser source assembly is the housing for the laser transmitter. This unit takes the modulated signal and converts it into the light beam that is transmitted.

H. LIDAR (LIGHT DETECTION AND RANGING) TRACKING

Laser communications that travel through the atmosphere have one major issue that transmission methods like radio or microwave do not. A laser system has an extremely small signal divergence. This divergence is one fact that makes communicating via a laser challenging. With such a small footprint, transmitter and receiver units must constantly track either end. The following description breaks down a simplified version of a laser tracking system.

This system example assumes that the system is transmitting a tracking beam that is being reflected off the receiver. The following tracking system has two main modes. Mode one is search (or Surveillance) mode. This mode is used to search for a receiver to be tracked. The second mode is the actual tracking mode. This mode maintains a favorable angle to the incoming beam. The tracking mode, in certain systems, can have two sub modes. The first is angle tracking. Angle tracking measures the incoming angle of the beam. The other sub mode is range tracking. Range tracking is used to measure the distance between the receiver and the transmitter. It not normally used but may be applied in certain situations.

The primary focus of this section is the tracking mode. This section assumes that the laser beam is locked on and tracking mode is initiated. For this example one target is moving. Only one end of the beam will be examined, however, one should consider that the same process could be happening at both ends of the connection if necessary.

As stated previously, the tracking mode measures the incoming angle of the laser beam. More specifically the tracking mode continuously estimates the target angle coordinates. The estimation is achieved by the use of a mosaic filter (or

sensor). Mosaic filters come in all shapes and sizes, however, for this example a quadrant detector/filter (QD) will be used to illustrate the idea.

Figure 13 is an example of a QD. Note that the sensor is broken up into four quadrants in the x,y plane. Each quadrant is isolated and has a device that converts the incoming light beam into an electrical current level. These currents are turned into the modulation frequency of the incoming signal and are then transferred to the signal processor for the remaining processing. Table 13 is an illustration of the tracking process for a QD. This process of updating spot coordinates happens continuously in this particular system. Now that the tracking process has been illustrated from a broad perspective, the actual spot measuring will be examined.

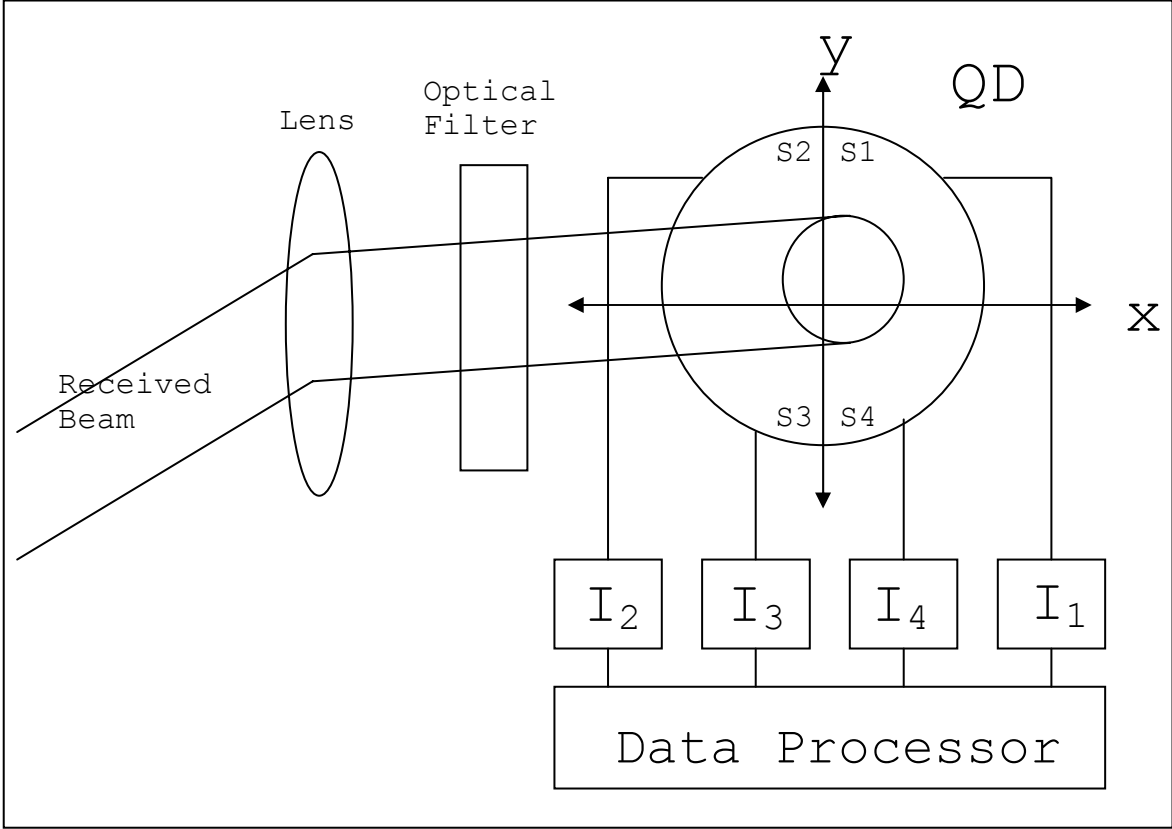

Figure 13. Quadrant Detector (QD) [After Ref 14]

Step	Detail
1. A beam falls on the input lens of the receiver	The beam arrives after being reflected from a target
2. The input lens concentrates the beam into a light spot of the surface of the QD	The optical filter suppresses background radiation
3. The light spot on the surface of the QD is given by a vector [(x,y) center of the circle]	
4. Once the (x,y) coordinates are estimated the angle of arrival can be computed	$\theta_x = \arcsin(x/F_c)$
	$\theta_y = \arcsin(y/F_c)$
	θ_x and θ_y are arrival angles measured from the system optical axis
	F_c is the system Focal Length

Table 13. Quadrant Detector Beam Tracking Process [Ref 14]

The measurement span (Figure 14) is the area of the QD that is illuminated by the laser beam. Beam coordinate estimation can be efficiently measured if the following two conditions are satisfied. The entire light spot is located within the QD area. If this is not met part of the signal is outside the QD and is lost. This causes considerable performance degradation. The other requirement is that each of the four detectors receives part of the signal. If this is not met then at least one photo detector is not receiving light or is only capturing the background field. One detector not receiving a signal offers no contribution to the computation and system degradation is felt.

The following is a brief explanation of the measurement span and the geometry that determines the (x,y) coordinates. Figure 14 shows the spot of light in the (x,y) plane. From the

figure one can see that the widest possible spot detectable is $d = D/2$, where d is the diameter of the light circle and D is the diameter of the QD. This equation assumes that the condition where the entire spot is located within the QD is satisfied.

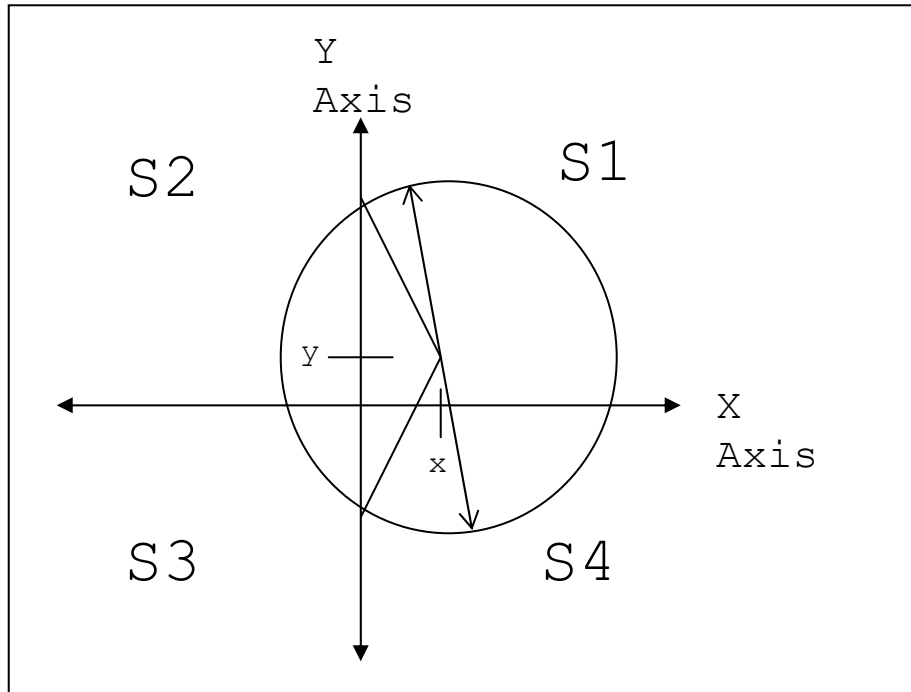

Figure 14. QD Measurement Span [After Ref 14]

The lidar system provides accurate angle and distance measurement to the tracked position in space. Depending on the implementation, this may or may not be the best method to implement the tracking feature. The following section illustrates another method to deal with the pointing and tracking issue.

I. BURST-METHOD TRACKING

Lidar scans allow a single laser unit to accurately track a single point in space. Another implementation of laser system tracking is called the burst-method. As the name implies, a system that runs under this configuration tracks its recipient for a period of time then transmits data for some prescribed time frame. This system is more advanced than the previous example and provides another way for communication to take place between two laser systems. Figure 15 is a basic block diagram of the burst mode system.

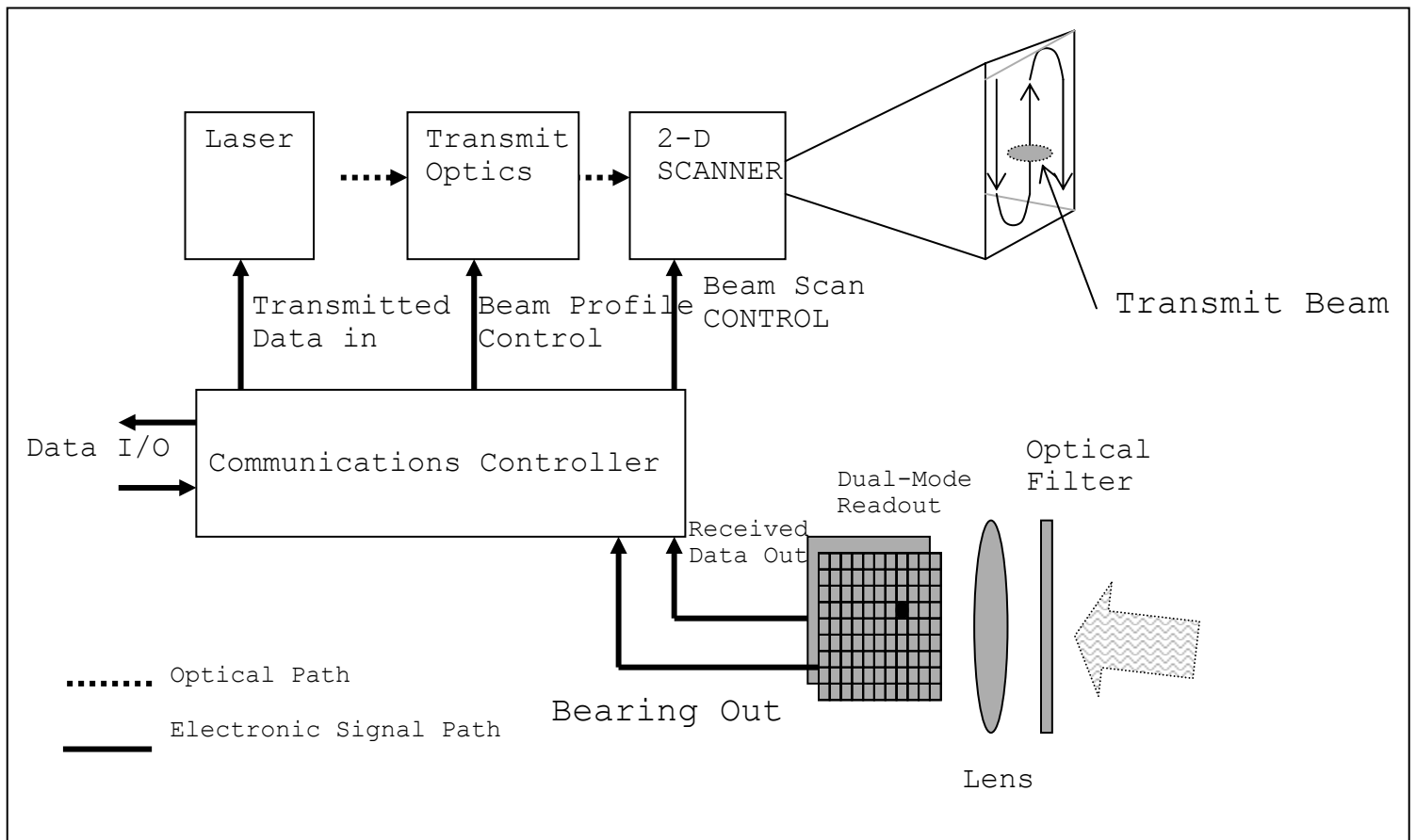

Figure 15. Burst Mode Block Diagram [After Ref 15]

This system also adds some features that the LIDAR system did not offer. It removes the need for each system to reflect a beam

off the intended receiver. Systems can search, completely autonomously, for another party. A burst system makes the following assumptions to initiate communication with another party:

1. Neither party knows the position of the other
2. Both system lasers are off
3. Receivers are in stand-by mode

Note that there would be an identical system on the receiver side. In order for two laser systems to begin communicating one system must initiate a search for a recipient. Tables 14-16 detail the track and lock-on process, which is broken down into three phases.

Phase 1	
Step	Detail
1. Initiator raster scans the search field using elliptical field	Initiator transmits a code of all ones (like a binary 1). This aids the recipient in doing a coarse acquisition of the initiators bearing.
2. Once the search field has been completed once a double loop raster scan is started	Again the system sends an all one code for bearing acquisition
	After the first loop is complete the initiator starts the second scan and transmits its identification-verification code (IV)

Table 14. Burst Mode Phase 1 [Ref 15]

Phase 2	
Step	Detail
Once the recipient identifies the initiator	The recipient steers a diffraction limited circular beam towards the initiator
	It then sends its IV code

Table 15. Burst Mode Phase 2 [Ref 15]

Phase 3	
Step	Detail
Once the initiator has verified the recipients code	Payload data is sent for a prescribed period of time
	Once the time to send data has expired, reacquisition is started. Reacquisition is a much faster process.

Table 16. Burst Mode Phase 3 [Ref 15]

This laser tracking system offers many benefits. The process of identifying the recipient and the transmitter prior to any data being sent secures communication. Also the receiving system does not respond to any transmitter without verifying its identity. This would keep an enemy from acquiring an accurate bearing to the receiver. This system also does not require a separate system for tracking and data transmission. Adjustments to a single beam can be made to allow for search, lock-on, and transmit. Currently this system is in development and has been demonstrated to operate at 1 Gbps over a 3km link. The two transmitting bodies had a relative speed of 660 m/s (mach 2) with a typical acquisition time of <100ms.

J. LASERS IN THE ATMOSPHERE

The use of lasers in the atmosphere offers many benefits over fixed wire, RF and other transmission methods. A laser

beam, however, has to deal with a number of issues that other mediums are less concerned with. The following is a discussion of the effects a light beam will encounter as it travels through the atmosphere.

Even on a clear day light rays traveling through the atmosphere are affected by various impediments. Laser light is also subject to these very same factors. Molecules like oxygen and nitrogen affect a beam as it travels through the air. Beams are also affected by pollution (in the form of aerosols) and weather-related phenomena.

The transmission of light through a turbulent atmosphere in the past has been a difficult problem. Today, the issues light beams must deal with are well understood. The following section breaks down the main effects or laws. [Ref 16]

Beer's Law is one of the most fundamental principles in the attenuation of light through the atmosphere. Beer's law determines the total attenuation of light as it travels through the atmosphere by both absorption and scattering. Beer's law is expressed by the following equation,

$$I_r/I_o = \tau = \exp(-\gamma x).$$

Transmission τ of radiation in the atmosphere is expressed as a function of distance x . I_r/I_o is the ratio between detected intensity I_r at location x and the initially launched intensity I_o , and γ is the attenuation coefficient.

The attenuation coefficient (γ) is made up of the sum of four individual parameters.

$$\gamma = \alpha_m + \alpha_a + \beta_m + \beta_a$$

1. α_m is the effect of molecular scattering
2. α_a is the effect of aerosol scattering
3. β_m is the effect of molecular absorption

4. β_a is the effect of aerosol absorption

This equation is a reflection of the total attenuation of various scattering and absorption processes. Each of these factors will be detailed more in the following paragraphs.

The term scattering illustrates the pinball nature of light as it passes through the atmosphere. The very nature of scattering is related to photons of light as they are redirected or redistributed as the beam travels. This process can have a dramatic effect on the amount of received signal.

Scattering, or Rayleigh Scattering, is named for the man who discovered a classic formula that is widely in use today. He showed that as the wavelength of a beam increases the effect scattering has on that beam increases. As a side note, as the wavelength of a beam move closer to infrared the effect Rayleigh Scattering has on a beam can be nearly neglected.

Another form of scattering is called Mie Scattering. This effect details the relationship between the size of an impeding particle and the wavelength of the beam traveling towards it. If the radius of the particle and the wavelength are the same the particle will have a larger effect on the beam. For particles larger than the wavelength, the effect is considerably less.

Along with scattering, absorption also has a significant effect on light rays traveling through the atmosphere. The amount of absorption a signal will have to deal with depends on the abundance of absorption impediments that beam confronts. These impediments are normally broken down into two classes. The first class is called molecular absorbers. Molecular absorbers are impediments like oxygen, nitrogen, carbon dioxide, and water vapor. For beams that reside in the IR range water vapor is the primary absorber. Figure 16 compares how IR beams

are affected by water vapor (Top) and carbon dioxide. It can be seen that water vapor is far more dominating than CO₂.

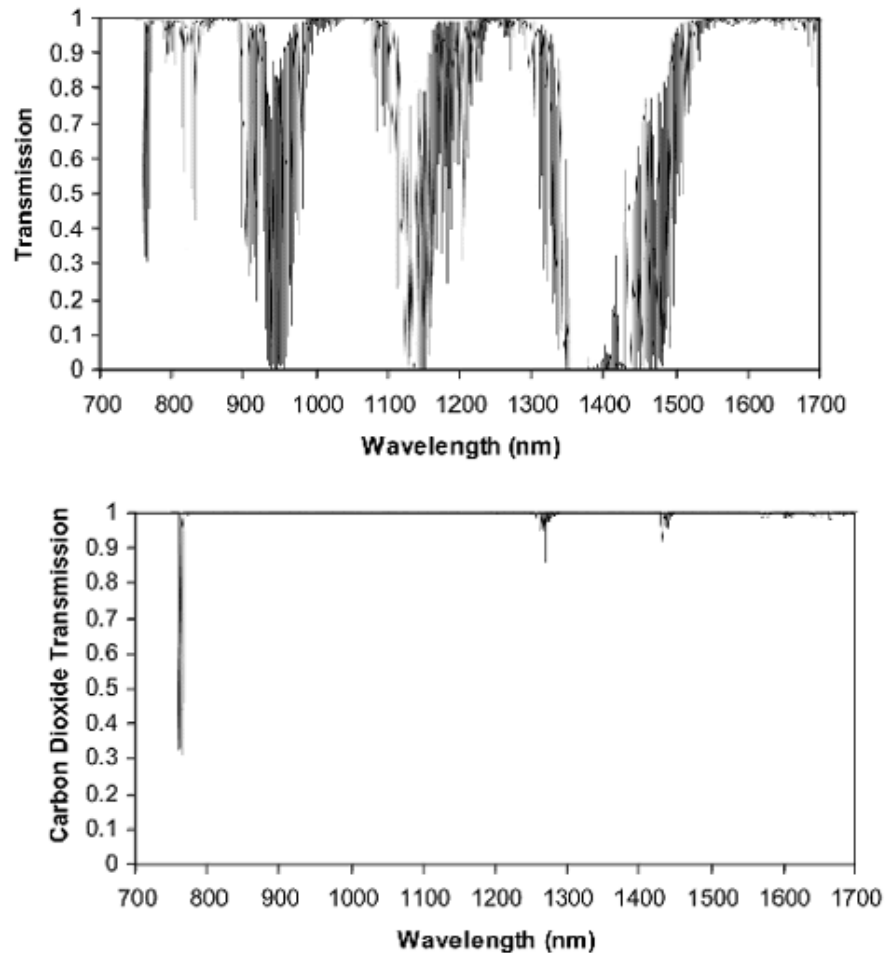

Figure 16. Absorption of Water Vapor (top) and of CO₂ (bottom) [From Ref16]

The other class of absorbers is the aerosol type. These impediments range from natural occurring to man-made aerosols. Natural occurring aerosols come in the form of meteorite dust, sea-salt, desert dust, and volcanic debris. Man-made aerosols are things like trace gases, solid particles, liquid particles, and industrial waste. Figure 17 shows the effect aerosols have on a beam relative to its wavelength.

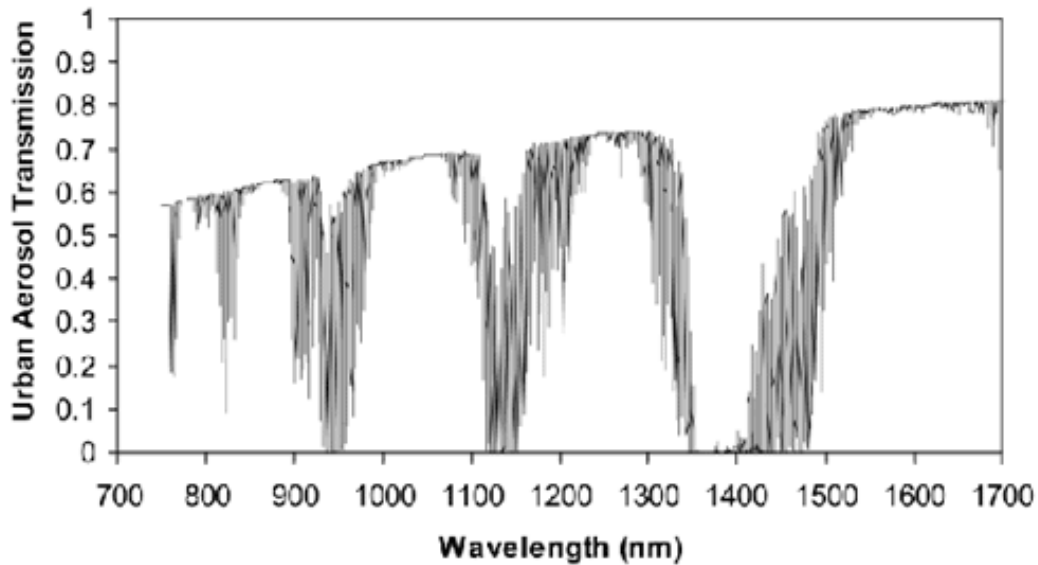

Figure 17. Absorption Curve with Aerosols [From Ref 16]

As was seen in the previous paragraphs scattering and absorption can have dramatic effects on a beam of light as it travels through the atmosphere. These effects, however, are not the only thing that a beam will have to deal with as it moves through the atmosphere.

Another effect on a beam is turbulence. Areas of that experience high levels of turbulence will add another factor to be considered when using light communication. As the ground is heated by the sun, certain portions of the air also warm up. Particular areas of the air can and often do heat up faster than others. These areas of air cells of varying temperatures manipulate the index of refraction in the air. These changes cause the path of the beam to appear to move. Because air cells are not stable they cause random fluctuations in the beam path relative to the observer. The change in beam path is called beam wander. This beam wander, like all of the previous effects, is different as the wavelength of the beam changes.

Another effect the atmosphere has on a beam is called scintillation. A mirage that appears on the ground as a lake is an example of this process. This effect causes random fluctuations in the wave front to the point where a receiver will go from having total signal loss to signal saturation. One thing to note about this process is the fact that scintillation only affects a beam traveling parallel to earth's surface and near the ground.

The previous descriptions have detailed many of the theoretical aspects that the atmosphere can have a light. The reader should understand that the previous section illustrates a number of effects the atmosphere has on light. The reader might get the impression that the atmosphere might not be a good place to transmit light for communication. All of the above effects are manageable; they account for some signal loss but that loss is not so great that the system is not usable. The next section will look at the more practical factors affecting laser communication.

K. WEATHER

It is important to realize the various influences the atmosphere can have on a laser beam. From absorption to scintillation, these theories play an important aspect in building competent laser communication systems. As important as these effects are to system designers, there are three others that will often dominate design requirements. Rain, snow and fog are three of the most highly attenuating effects that a system will have to deal with.

Rain has a distance-reducing impact on a laser beam but this effect can be manageable. A raindrop has a radius that is much larger than the wavelength of a typical laser communication system. As stated in the previous section, impediments that are

much larger than the wavelength have less of an effect. In a typical rain storm (2.5 cm/hour) attenuation of the signal is around 6 dB/km. [Ref 16] This loss must be accounted for, but it is manageable. One should keep in mind the fact that even though rain losses are fairly low the volume of rain falling will change the amount of attenuation. During a cloudburst (>10 cm/hour) signal losses can be extreme but these bursts normally only last for a few minutes.

Similar to rain, snow also attenuates the signal. As one might realize, snowflakes are even larger than raindrops and offer about half the losses of rain (3 dB/km). Just like in the rain example, the rate of snowfall will add to signal losses.

Finally, and by far the most detrimental portion of weather losses, is fog. This weather phenomenon causes the most problems for laser communications systems. Fog droplets are smaller than snow and rain and their radii are very close to that of IR wavelengths. Fog, just like rain and snow, will attenuate the signal more as the amount of fog increases. Because fog is less understood than rain and snow, its severity is normally understood in words rather than volume over time. Fog levels are detailed in terms of thick and thin. It is also detailed by the visibility that it allows. As an example, visibility less than 2000 meters is often referred to as foggy. When visibilities are greater than 2000 meters but restricted, the term hazy is used. Table 17 shows the effects fog has at varying levels. [Ref 16]

The effects of weather can offer considerable restrictions to laser communications. The next chapter will illustrate some of the actual technology that is currently being designed for use in the military and the commercial sector. Even though weather can have a tremendous effect on a laser signal

technology has provided ways around these limitations and the true power of laser communications can be seen.

Weather Condition	Precipitation		Amount mm/hr	Visibility	dB Loss/km
Dense fog				0 m, 50 m	-271.65
Thick fog				200 m	-59.57
Moderate fog	snow			500 m	-20.99
Light Fog	snow	Cloudburst	100	770 m 1 km	-12.65
					-9.26
Thin fog	snow	Heavy rain	25	1.9 km	-4.22
				2 km	-3.96
Haze	snow	Medium rain	12.5	2.8 km	-2.58
				4 km	-1.62
Light haze	snow	Light rain	2.5	5.9 km	-0.96
				10 km	-0.44
Clear	snow	Drizzle	0.25	18.1 km	-0.24
				20 km	-0.22
Very Clear				23 km	-0.19
				50 km	-0.06

Table 17. Fog Effects [From Ref 16]

L. BRINGING IT ALL TOGETHER

So far this chapter has outlined much of the technology that makes laser comm. a reality. However, by providing the information on the obstacles such as weather or beam tracking, the system might seem unfeasible. Fortunately, this is not the case. Some of the brightest minds in the communications industry have been working on solutions to the issues regarding reliable laser communications. This section intends provide answers to many of the frequently asked questions that relate to making these systems work.

One of the first questions that is asked about laser communications is - "What about fog?". The reality is that fog is one of the primary attenuators to a light beam. That does not mean, however, that nothing can be done about it. Regardless of the thickness of fog through the atmosphere, systems can be setup to deal with the situation. First, the received signal regardless of fog thickness depends on the length of the connection and the output power. Both of these can be simply adjusted to aid signal gain at the receiving ends. Special transmitters and receivers have been designed to deal with fog. Research has shown a 1 Gbps connection over a 1km link through dense fog was possible. Fog can make laser links more challenging but it is by no means a shown stopper.

The next most often asked question is - "What if a bird or other obstruction moves in front of the beam?". Temporary obstructions provide little to no degradation in the signal. This is because networks are set up in packet switch formats so that information can be retransmitted if lost. With obstructions, fog, and any other type of laser issues, 300meter links between buildings have been shown to have 99.99% uptime

during the course of a year. This relates to about one hour of down time spread out over the year. Hardwired systems tend to have slightly more downtime than this because of the many forms of interference they have to overcome.

As mentioned in the previous sections scintillation is looked at as a serious issue for laser links. This effect is not necessarily a frequently asked question but it too has a solution. Remember scintillation is the fluctuation of a received signal from turbulence in the atmosphere. One way around this is by providing aperture averaging. This process looks at the average signal value when processing the signal back to an information bit. Also, special receiver designs have been used to overcome much of the problem.

Another issue solved, which is closely tied to scintillation is spot dancing. A fixed beam can appear to move around the receiver's detector because of atmospheric affects. The solution for this is called the delayed diversity scheme. Basically, data is sent twice in two separate wavelengths or polarizations. A delay is added between the two transmissions that is longer than the correlation time in the atmosphere. BER is reduced (which is good) because bits can be detected again for comparison.

The next set of questions is steered more towards the semantics of topology rather than weather. The decision regarding when to use an RF or laser link is important to understand. The commercial sector may find this situation easier to handle; if one service is not available then switch to the other. Naval ships may not have the luxury of transmitting with RF because operational concerns make this transmission a security risk. On a ship at sea, if a laser link is lost for some reason it may not be desirable for the system to

automatically switch to microwave (RF). A facility to control this process would need to be inserted to ensure redundancy is possible without creating security issues. This problem, however, is easily overcome with an operator setting the system to meet current mission specifications.

Another topology issue is the handling of discovery and monitoring of laser links. Currently, the process of routing traffic on the Internet uses an automatic node discovery system to create a table of connections and their respective distance (measured in hops counts). These tables are updated at specified time intervals and require no user input. They provide information on what node they are connected to and who that node is connected to. This allows for dynamic routing and the ability to create fault tolerant and efficient multiple paths to various nodes.

Monitoring, for a laser link, is slightly more interesting than a landline but solutions are available. Laser links need to be monitored not just for link available/not available and distance messages. They also have to consider received power, current BER, fade, and obstruction. Scientists have developed heuristics to handle the decision process of how to route traffic in a wireless situation. The discovery and monitoring process time by current algorithms is currently measured in milliseconds (usually less than 10 with a portion of that time going toward beam steering)

With the groundwork for laser networking in place, potential applications and upgrades can now be examined. The next chapter provides a few real-world examples of laser communications systems and some networking opportunities that are available.

III. CURRENT TECHNOLOGICAL DEVELOPMENTS

The previous two chapters have illustrated a need for an increase in bandwidth and the systems that makes laser communications possible. This chapter is intended to provide the reader with some of the corporations that are working on laser systems, a current DoN developmental system, and some of the possibilities laser systems could provide within the framework of the Navy's future plans.

A. FREE SPACE OPTICS

Up to this point the author has used the term laser communication to reference the topic system. The corporate terminology for the same system is called free space optics (FSO). The term FSO and laser communications are synonymous and both terms should be used when researching further information on this subject.

The primary motivation for the commercial application of FSO is for line of sight networks from fixed locations. Companies are starting to realize the benefits of creating their own private networks between neighboring locations without having to create expensive fiber optic or copper lines provided by the phone company. FSO provides a company with the flexibility to quickly and cheaply include another location within a network or provide an uplink to the Internet. There are a number of companies that are becoming leaders in this technology. The following are only a few examples of companies that are involved in FSO/lasercomm endeavors.

The Terabeam Corporation [Ref 24] is one company that is expanding the prevalence of FSO systems. Their Elliptica series

systems offer a 1540nm and 1600nm beam with ranges up to 4km and data rates up to 155Mbs. Currently Terebeam is in its fourth generation of point and tracking systems and they use a 200Hz closed-loop narrow beam tracker. Terabeam systems also offer simple one-person installation and alignment. All of their units provide self-optimizing and alignment equipment to maintain high quality links without user input.

The Cannon Corporation [Ref 25] is another manufacturer of FSO systems. Their DT series provide a similar service to the Terabeam systems. Their implementation provides service by using a 785nm beam to a distance of 2km with transfer rates up to 655Mbps. They also offer simple installation and maintenance, recommending that laser diodes and tracking systems only be inspected every two years.

The final company that will be discussed is AirFiber [Ref 26]. Their AirFiber 5800 uses a 785nm beam with transfer speeds up to 655Mbps. One unique fact about this company is that they claim a BER of 10^{-12} with the use of an Active Redundant Link Controller to mitigate data loss in inclement weather. To put this into perspective a BER of 10^{-12} is normally the bit error rate of fiber optic lines.

Each of the above companies provides a particular system to meet corporate networking needs. This need is very similar in the Navy but the structure these systems will ride on is quite different. All of these systems are placed on buildings at fixed locations. Even though large buildings sway with changes in wind and temperature these systems are not currently designed to perform on a ship. The next section is an illustration of a DoN implementation of the technology designed, in part, by the commercial sector and placed in the Naval battlefield.

B. PROJECT SALINAS

Currently, the Lawrence Livermore National Laboratory (LLNL) in Livermore, CA is working on a laser communication system which is very similar to the one illustrated in this paper. The project is broken into two independent projects. The first is called SALINAS [Ref 31] (Secure Air Link for Naval Airborne Sensors) that intends to provide a joint sensor-to-shooter system to help eliminate the bottleneck to Total Situational Awareness. This project, which is not the focus of this paper, will use LLNL's advances in a project called SATRN. SATRN or Secure Air-optic Transport and Routing Network will be the backbone for the information/sensor system. Unlike the technology provided by the corporate sector, SATRN [Ref 32] is designed to be installed on moving platforms such as ships, aircraft, UAVs, and movable ground stations.

So far project SALINAS and SATRN are illustrating the benefits of laser comm. and the potential it has on future operations. The data in Table 18 are a few examples of the opportunities high capacity laser comm. links from LLNL would provide. Table 19 illustrates some of the platforms where this system is compatible. Along with the flexibility of installation on many platforms types, this system provides a number of benefits over current microwave technology (Table 20).

Example	Benefit
Data Fusion for sensor-to-shooter systems and broad area search	Hyperspectral imaging system and SAR
	Panoramic high resolution video
	Data from large sensor networks
Multiplexed data lines	Networking and data routing of Sipernet
	Tele-maintenance
	Tele-medicine

Table 18. SALINAS and SATRN Opportunities [Ref 31]

Ship-to-shore
Ship-to-ship
UAV-to-ship
UAV-to-high flyer
high flyer-to-ship

Table 19. Potential SALINAS/SATRN Platforms [Ref 32]

Less weight, power requirements, and size
Higher data rate capability
Low-probability of intercept, detection, or jamming
Allows for data transfer for covert operation when RF/Microwave emissions are forbidden

Table 20. Benefits Over Microwave [Ref 32]

Currently this system offers multi-gigabit transfer rates and burst-mode operation. Similar to what was mentioned in the previous chapters, high data rates are desperately needed, however, their usefulness is limited if they are unable to work

in all weather conditions. The SATRN project laser system uses a mid-IR beam, which can penetrate blue-green water and fog. This systems burst-mode capability also allows data to be cached and retransmitted if necessary in poor weather conditions.

For the baseline system in FY02 used a single channel 2.488Gbps transfer rate with a BER of 10^{-4} to 10^{-5} . Using a multiple channel link the system has run at 10 Gbps. The FY03 system is scheduled to run at 100Gbps. To provide the reader with an example of how much bandwidth this is imagine the system running one channel at 2.488Gbps. Table 21 shows the level of bandwidth equivalent to this *single* channel. The 100Gbps system is almost 50 times faster than the previous single channel example and would open communication opportunities that are almost limitless.

1600 T1 Lines
400 TV Channels
40,000 phones
1600 lbs of paper with text per second

Table 21. SALINAS/SATRN Single Channel Equivalence [Ref 32]

C. NETWORKING REVIEW

The purpose of this section is to give the reader a brief summary of components and design of modern computer networks. This refresher will provide definitions and details that will be critical for understanding the following section. Readers who feel confident with computer networking may want to skip to the next section.

The primary and most fundamental term to understand in computer networks is the Node. A node can be any device that

uses a network. A node can be a workstation, printer, router, server, scanner, or copier. These devices all constitute nodes on a network. The simplest type of computer network is two nodes connected via some medium. The connection medium can be coaxial cable, twisted pair cable, air (RF), laser, or fiber optic cable. The connection of two nodes directly is called Point-To-Point (Figure 18). As the name implies, there is a direct connection between two parties. An example would be two computers connected together sharing files. As shown in Figure 19, nodes not only represent singular entities but groups of nodes. Regardless of what a node represents, a point-to-point (PtP) connection between two nodes is direct.

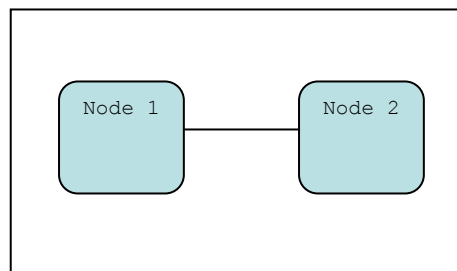

Figure 18. Point-To-Point Connection

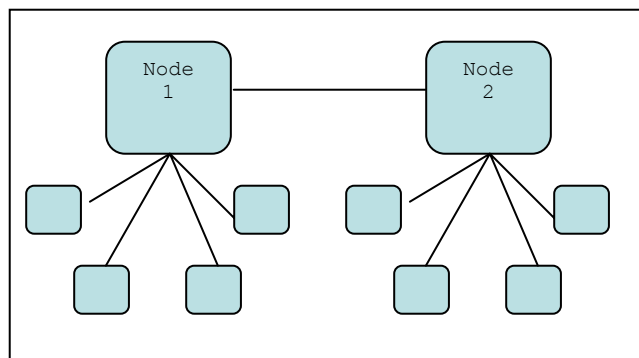

Figure 19. Point-To-Point Between Networks

Groups of nodes are organized into network structures that fit their intended use and hardware design. Network topologies have changed over the years but the two most widely used are

Star and Ring. The star topology allows each computer to communicate without the assistance of other nodes. The Ring topology (Figure 20) requires each node to connect to other nodes by passing packets from node to node. Switched networks (the most widely used) are designed around the star topology (Figure 21). This is the primary network design used by the Navy and on the Internet. From this point on the reader should assume the network topology used is Star unless specified.

As mentioned previously, switched networks are the most widely used. Switches are an improvement on a device called a hub. A hub was an appliance that allowed multiple nodes to connect to a central box. This allowed networks to increase the number of nodes beyond two. Basically a hub has multiple connections going to various nodes. Each node will have an interface card that allows it to communicate on the network. A hub (Figure 22) provides a common or shared medium to connect all nodes on the network. The bandwidth available on a hub is limited to the interface cards in each node and the amount of traffic generated by each node. The major problem with hubs is the fact that two nodes can attempt to talk to the network at the same time. This condition is called a collision. A number of software and hardware fixes have been created to deal with collisions. On the hardware side a hub was upgraded to a device called a Switch.

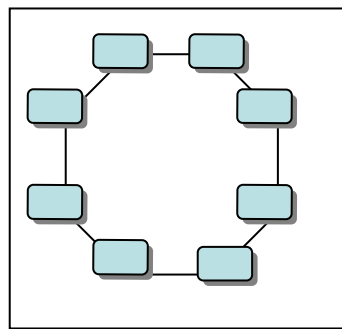

Figure 20. Ring Topology

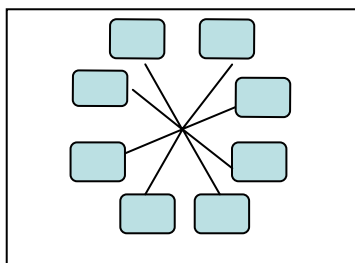

Figure 21. Star Topology

A switch (Figure 23) provides a specific connection for each node to every other node on the network. This allows two nodes to communicate at full speed without being concerned with the communication of other nodes on the network. This increases the overall available bandwidth and nearly eliminates the chance that a collision can occur. A switch facilitates communication between nodes, however, it does not provide nomenclature to allow each node to be an independent network entity. Each node must have a unique identifier or address.

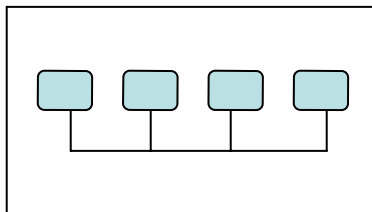

Figure 22. Hub Architecture

Another important aspect of network design is addressing. Each node on a network must have a unique address. Currently IPV4 is the addressing scheme for the Internet, DoD, and most corporate networks. It uses four three-digit numbers from 0 to 255 (in base ten form) to create a single address. An example address is 192.168.0.1. The power of these addresses lies in their ability to be broken down into smaller networks called subnets. A subnet is a range of addresses on the same network. Each node within a subnet can communicate with any node in the

subnet without assistance from another node. A node that wants to communicate to another node outside the subnet is required to use another node that is connected to a larger body of nodes that contain the node with the desired address. In summary, nodes use their individual addresses to identify each other and determine location (within the subnet or not). In order for the machines on the network to communicate they must have a standard language or protocol.

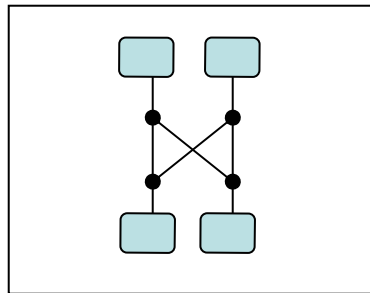

Figure 23. Switch Architecture

Today, computer networks primarily use TCP/IP as the communications protocol. A communications protocol is the language two nodes use to communicate. The most popular services on the Internet use TCP/IP. Services such as email, web pages, file servers, and chat rooms all use TCP/IP. The TCP portion of the acronym stands for Transmission Control Protocol. The IP portion stands for Internet Packet. Together they provide addressing and session management to allow multiple nodes on a network to communicate at virtually the same time. This is the primary means of communication for Naval networks. Because TCP/IP is an open protocol (no corporate control and source code is freely available to the public) it is well understood and very robust.

D. POSSIBILITIES

Ships at sea that can connect to other entities through high-speed data lines with adequate range have a number of networking possibilities. Ships in this scenario go from isolated entities to members of a network. This network could support many of the functions and capabilities of land-based networks. The following section illustrates some of the data flow possibilities for ships with these capabilities.

For a moment, think of a ship as a floating network rather than some type war-fighting platform. If the resources within the ship are connected with standard protocols, the only limitation to creating a tremendous data gathering and generating platform is the ability quickly transfer information off ship. With laser networking, ships can have near fiber optic throughput to share data with neighboring entities.

If our ship example is now a floating network then that network can be abstracted to a single node, which represents the network or a group of nodes contained within. Now our ship has gone from an isolated vessel to a group of locally connected nodes that are brought together by the ship's network. The connected nodes are then represented as a single node (the ship itself). This abstraction may seem unnecessary at first but it will become important later in the discussion.

A laser communications system between nodes (ships at sea) creates a new paradigm for ship-based communications. Currently, when a person generates an email that is destined for someone outside the ship that email sits on an internal server, on board until a satellite link is made. Once a satellite connection is initiated email is uploaded to a remote server (land based) via satellite. Once all queued messages are sent, the server will

download new messages waiting for recipients on that particular ship. This method of email transfer is actually the standard for the Internet. However, with high-speed point-to-point connections this is not the best way.

When I generate an email from home my computer, the message is sent via a fixed networking scenario. I will have been assigned a particular IP address, subnet mask, gateway, and DNS server. This information will not change at all during my connection; if it does, I will not be able to communicate with the network. If I were a moving node (think cell phone user in a car) I could be entering and leaving networks in real time. This is very similar to what a ship would go through. Laser comm. connected networks/nodes will need to connect in an ad hoc fashion and be able to announce who they are and what services are available. If my email were destined for a recipient in a network that I am currently connected to it makes sense to send that email directly to the email server in that network. In our current situation, even if I was connected to that network directly my email would go to some other server and wait for the recipients email server to grab the message and pass it to the appropriate inbox. Figure 24 illustrates the current networking situation for email distribution used by the Navy for ships at sea (letters represent ships). Figure 25 shows how a directly connected ship could bypass the land base server and send it messages right to recipient. Figure 26 shows a more advanced version where ship B acts as a router to ship C. Again, this completely bypasses the satellite link and land-based server.

This example might seem complex but with the prevalence of wireless networks, the software has already been written handle these ad hoc connections. There is an open-source consortium that has created a protocol for nodes on an IP network to auto

detect each other in real time and determine who they are and what resources they are sharing. The protocol is called Zeroconf [Ref 27]. The idea to enhance IP networks in wireless conditions has found considerable corporate support in the past few years. Apple Computer has taken Zeroconf and integrated into their current operating system and has renamed it Rendezvous [Ref 28].

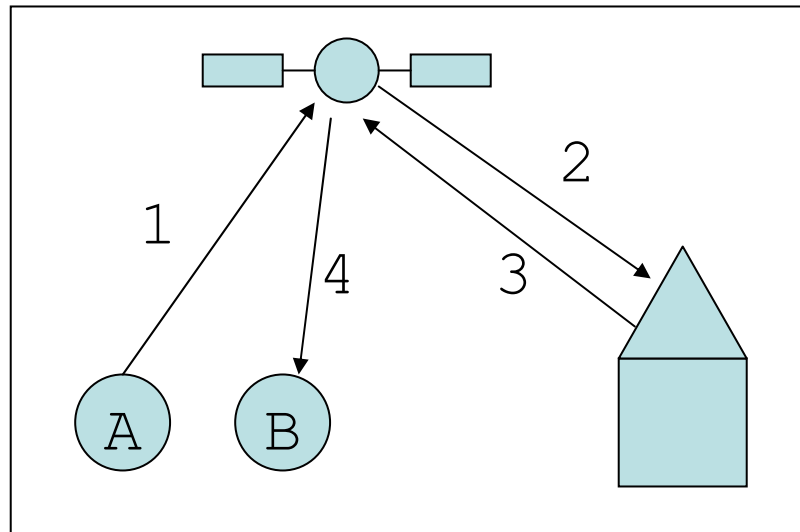

Figure 24. Current Email Distribution Steps

When two Apple computers meet for the first time (the assumption is made that both machines are running their network interface cards) they will announce themselves in a broadcast message. Each user will get a message in the application they are using (if appropriate) that lets them know a new user has joined. This message depends on the application each person is using and if they are open for connection. If both people are using an ICQ chat program, they will be added to each other's buddy list automatically. No user intervention is required. If one person leaves or terminates the connection his/her name is removed from the buddy list automatically. With laser networking, server based applications could perform the same functions and Apple's local paradigm.

With Zeroconf/Rendezvous at the server level and a laser comm. link, two ships could announce who they are and what services they have to offer. This would all be automatic and completely self-contained. The following paragraphs provide examples to illustrate how this network paradigm could simplify the way users exchange data.

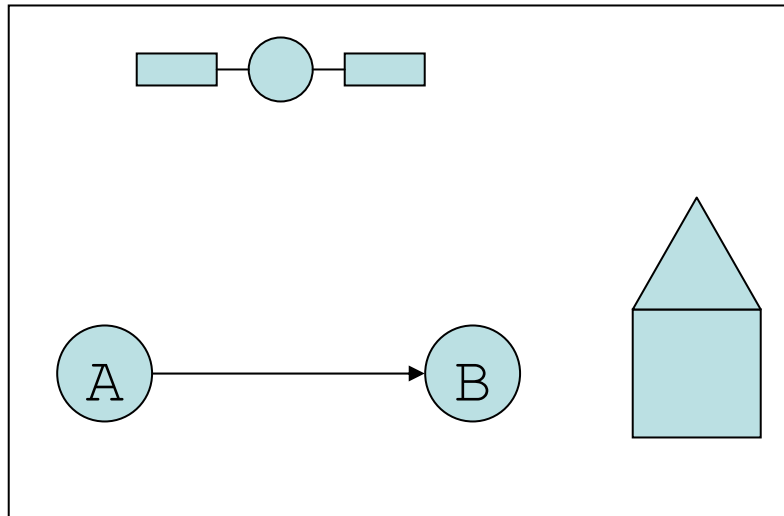

Figure 25. Directly Connected Link

One of the major challenges for network administrators in IP based networks is providing users simple methods for connecting to network services. Those services range from printing, file server access, email, and Internet access. Often, each individual computer on the network must be configured to with specific print drivers or configured to allow server access. If devices like servers or printers could announce their presence, computers within the network could automatically configure themselves with drivers and IP address information. This idea is great for the local IP network but it is also possible for two networks coming together for the first time.

networks connected, large amounts of data could be transferred quickly with no user configuration. Both ships supply databases could perform updates with transferred data on the goods and fuel before any lines have crossed. These data updates could be routed to their respective recipients to make preparations.

Another possibility is phone communications. If two networks can connect and exchange services that they offer there is no reason that phone calls could not be routed between ships. Upon connection each ships server could provide phone number data and instruct phone systems to route phone calls to the other ship. Under this scenario, if a user wanted to call a member of another ship he or she would check the server-based phone list for the person they want to call. The server would give them a list of people and numbers for the other ship. They could then pick up the phone and dial that person directly.

This direct dialing and network access is important to at sea communication but there are more possibilities. Today, when a ship is heading towards a pier they can not have phone or data network links established until physical hardwire lines are brought over and connected. With a laser link the ship could have access to phone and data networks way before the ship is moored. Ships that are anchored could connect to a land based link and conduct business as if they were attached to the pier. These links too could be completely automated.

Again, the important aspect of this entire section is removing the requirements for a user to configure these systems. With automated network detection and service information transfer fewer people will be needed to make these new and advanced ways of communicating possible. Reduced manning and improved data throughput is an extremely important aspect of

future Navy operations, automated network detection with laser comm. links could be one means to moving towards that future.

E. INTEGRATED COMMAND ENVIRONMENT

In the spirit of transformation and transporting Naval ships into the future, NAVSEA, Office Naval Research, (ONR), DDGX program office, and others are developing a system called the integrated command environment (ICE) [Ref 29]. This program is designed to create a new way of running command and control of the Navy's warships with reduced crew size and individual workloads.

ICE is very similar to the total ship monitoring mentioned in the first chapter. Basically, the majority of the ship systems that currently require watchstanders to physically operate and/or walk around and take hand written logs will be replaced with automated systems. Watch stations will then be able to be combined into a single watch monitored by one person at some central consol. The real heart of this system is its command and control center where the senior watch personnel monitor, organize, and prioritize the environment, ship, and crew.

The center of the command and control structure for DDGX is being designed to provide highly integrated and centralized watch stations with various forms of redundancy. The central command and control space is a room with large displays on the wall and eight redundant workstations set in some circle-like shape so that all watch standers can face each other. Each workstation has a series of four flat panel monitors arranged with three vertical and one at the keyboard level. The three vertical are set with one to the right and one to the left set

at a forty-five degree angle. Between these two is another directly facing the user. The fourth screen sits just above the lap of individual nearly facing up. Each screen is touch sensitive and allows users to get input and provide output without looking down at a keyboard. Another benefit of these stations is the fact that every station is generic, should a failure occur at one terminal the user can move to an empty station and resume right where they left off.

This system will normally have six people standing watch with an empty terminal for the commanding officer and one for redundancy. The watch structure has seven stations - command, command action officer (CAO), air warfare coordinator, land warfare coordinator, sea warfare coordinator, ship control officer, and ship systems officer. Command is the station occupied by the commanding officer. This station is manned at the CO's discretion. It operates in the same way a CO might on any current ship. The main difference here is that the CO can talk face-to-face with all of his senior watch standers and by request can see the exact same picture of the environment they have. The CAO station is a combination of the tactical action officer and the officer of the deck (minus ship driving). The air warfare coordinator's responsibility is to maintain a real-time picture of the air environment and current air weapons systems. Land warfare coordinator is the fourth station in the center. His or her responsibility is over ship guns, tomahawks, and UAV monitoring. This watch is intended to aid the ground warfare teams from the sea. The fifth station is the sea warfare coordinator, whose responsibility is to maintain the surface, subsurface, and mine picture for current operations. The next station is the ship control officer. This station actually drives the ship. Their responsibility is to maintain course,

speed, and navigation for safe ship operations. This station may also have an actual watch stander in the control room to ensure that speed and course orders are being answered correctly and that there are no conditions out of the sight of the control officer. This station is important because the ship control officer may not be facing forward (relative to the ship) and could get confused in high sea state or traffic situations. The final station is the ships systems officer. This watch combines the engineering officer of the watch (EOOW), combat systems officer, and damage control officer (in case of casualty). The watch will become damage control central for all casualty situations.

The goal of this system is to take the current requirements of having 25-40 senior watch standers running the ship to 7-10. This becomes a reality because of the amount of information available to watch standers. As an example, each crewmember will have a locating device (with built in health monitoring) that will provide their location throughout the ship. If a compartment needs to be sealed because of flooding or fire it can be verified clear remotely. Watertight doors can also be monitored and operated remotely and their status can be verified as it relates to the current condition set.

This system takes advantage of a number of developments in technology, organizational research, and fleet experience; however, it has a tremendous need for flexible, high-speed, and highly available bandwidth. For each watch station to maintain a clear and accurate picture there must be a number of connections from within the ship and without. Shared awareness through data, voice, text, and video must be instantaneously available. Currently, the Navy's information technology within a ship is moving towards the ability to fulfill the required needs. The

connection between ships, however, is in need of some work. Ship microwave links will not even come close to handling throughput needed to drive this paradigm. Satellite links are also not as robust as would be required to maintain this system. The only system, currently, with enough throughput and flexibility for ships at sea is laser comm. Table 22 is an illustration of the links laser communications could provide the integrated command environment. The future for the surface warrior is bright with advances such as ICE but the communications barrier must be overcome for any of this technology to be exploited in the way it was designed.

Connection	Benefit
Supply Chain	Access to local and remote supply inventories
Data Links	Quickly access remote data
Crew location / Health	Remote monitoring of ship personnel
Video Teleconference	Live video from ship to ship
UAV	Download sensor data including Video, pictures, ETC.
Network Security	Laser links are nearly impossible to jam, intercept, and detect

Table 22. Integrated Command Environment Benefits [Ref 29]

F. ADDITIONAL CAPABILITIES

The primary focus of this paper up to this point has been centered around the idea of placing laser links on Navy ships. The reader should not walk away from the paper with the idea that ships are the only platforms capable of supporting this type of equipment. Very similar to what was mentioned in the section of project SALINAS, laser links can be designed for many different platforms for various missions.

One of the newest and possibly most important platforms that could benefit is the unmanned airborne vehicle (UAV). With the multifaceted joint mission capabilities and low cost of UAVs, commanders from various services could use laser links to transfer many different types of data.

The sensor capability of a UAV offers many benefits over manned airborne vehicles. With these benefits, however, come tradeoffs in data storage and transportation. A UAV may be able to capture tremendous amounts of data over the battlefield but if that data cannot be examined in real time then UAV effectiveness is limited. With a laser link, data could be downloaded quickly and in real time to give commanders an up close look at areas not safe for soldiers.

Another important benefit of having a UAV for wireless networking would be using them as nodes in an airborne network. UAVs could extend the line of sight range, provide redundancy, and increase bandwidth for the battle space network. UAVs could also become links between ships or shore facilities to shorten the laser link distance in inclement weather.

The last possibility to be discussed is the benefits that could be provided to soldiers on the ground. Truck-based stations could be setup to link a shore base to a ship at sea

via a UAV. Soldiers on the ground could also get the same sensor data by downloading it from a UAV in flight over a particular area. Because laser links have extremely high bandwidth, ground personnel would only to connect for a moment and all requested data (previously queued) could be sent in a burst style connection.

The possible connections for laser links in future battle space networks has nearly unlimited possibilities. From ground to air, air to ground, air to air, or ground to ground, nearly all military platforms can benefit from high-speed laser links.

THIS PAGE INTENTIONALLY LEFT BLANK

IV. SUMMARY

From transferring email to live video streams, commands at sea are feeling the strain of not having a data pipe large enough to conduct operations. The bandwidth crunch has reached a point where policies detailing how PowerPoint presentations are constructed or whether or when a UAV can fly are being drafted. These limitations are hurting overall fleet effectiveness. The current problems with communications links must be solved before the fleet can progress into a smaller, faster, and more flexible system. High-speed wireless networks for moving platforms such as ships are in the Navy's future. The only question outstanding is which implementation will be used.

Laser communications are an asset with nearly unlimited potential. They offer extremely high bandwidth, scalability, and simple integration into the fleet without disruption to current RF-based systems. Connections into the current computer network structure would require little to no cost because both systems support standard interfaces and open protocols. Additional ship upgrades could be added at the network level, which provides considerable flexibility. New server-based systems could be installed anywhere on the ship and could be connected right into the ship's LAN without having to upset ship's layout. Laser systems also provide other cost savings because of their scalability.

Laser networking does not require a large infrastructure to be in place in order to provide service. System deployment could be done in very flexible phases. An entire battle group could be fitted at once or the system could be tested on a couple of

ships. Either way, it offers low cost testing with the end user providing immediate feedback and recommendations.

Laser links are the answer to the fleets need for high-speed wireless communications. They offer the most throughput, reliability, and security compared to any wireless communications standard to date. With the tremendous evolvement of corporate America and the Department of Defense, communication with lasers has an extremely bright and limitless future.

LIST OF REFERENCES

1. Wired News, "Military Faces Bandwidth Crunch."
[<http://www.wired.com/news/infostructure/0,1377,57420,00.html>]. March/2003.
2. Navy Office of Information, "Current Testimony."
[<http://www.chinfo.navy.mil/navpalib/testimony/testimon.html>]. January/2003.
3. Alberts, David S., Garstka, John J., and Stein, Fredrick P., Network Centric Warfare, CCRP Publication, 1999.
4. Defense Technical Information Center, "Joint Doctrine for Information Operations."
[http://www.dtic.mil/doctrine/jel/new_pubs/jp3_13.pdf]. March/2003.
5. PC World, "Navy Prepares to Navigate With Wireless LANs."
[<http://www.pcworld.com/news/article/0,aid,109053,00.asp>]. January/2003.
6. Laser Stars, "Microwave Laser."
[<http://home.achilles.net/~jtalbot/history/ammonia.html>]. January/2003.
7. Laser Stars, "Optical Laser."
[<http://home.achilles.net/~jtalbot/history/ruby.html>]. January/2003.
8. How Stuff Works, "How Lasers Work."
[<http://science.howstuffworks.com/laser.htm>]. January/2003.
9. Defense Technical Information Center, "Military Critical Technologies List."
[<http://www.dtic.mil/mctl/DCT/DCTSec11.pdf>]. January/2003.
10. Goodwin, Frank E., "A Review of Operational Laser Communications Systems," in Free-Space Laser Communications, David L. Bergley, Editor, SPIE Milestone Series Volume MS 30, pp. 3-9. (1991).

11. Technology at Niagara College, "Optic/Optical Fiber Principals."
[<http://www.technology.niagarac.on.ca/courses/phtn1220/notes/phtn1220tx.ppt>]. January/2003.
12. Technology at Niagara College, "Optic/Optical Fiber Principals."
[<http://www.technology.niagarac.on.ca/courses/phtn1220/notes/phtn1220rx.ppt>]. January/2003.
13. Lopez, J. M., Young K., "Acquisition, Tracking, and Fine Pointing Control of Space-based Laser Communications Systems," in Free-Space Laser Communications, David L. Bergley, Editor, SPIE Milestone Series Volume MS 30, pp. 145-159. (1991).
14. Kazovsky, Leonid G., "Theory of tracking accuracy of laser systems," in Free-Space Laser Communications, David L. Bergley, Editor, SPIE Milestone Series Volume MS 30, pp. 168-176. (1991).
15. Department of Electrical Engineering and Computer Sciences University of Berkley, "Publications."
[<http://www.eecs.berkeley.edu/~jmk/pubs/stab.overview.leos.11.02.pdf>]. April/2003.
16. InformIT, "Making Free-Space Optics Work."
[http://www.informit.com/isapi/product_id~%7B8F4793D0-C388-4726-96FD-B81976F165D8%7D/content/index.asp]. March/2003.
17. Weisman, Carl J., The Essential Guide to RF and Wireless. Prentice-Hall, 2002.
18. Hecht, Jeff, Understanding Fiber Optics, Howard W. Sams & Company, 1987.
19. Government Computing News, "Navy needs more and smarter ships, commanders say."
[http://www.gcn.com/vol1_no1/daily-updates/20880-1.html]. January/2003.
20. Government Computing News, "DOD brass: Afghanistan campaign strengthened battlefield comm."
[http://www.gcn.com/vol1_no1/daily-updates/20873-1.html]. January/2003.

21. Baars J.M., Witiw, M., Al-Habash, A., Fischer, K.W., "Effects of Low Clouds on Terrestrial Free-Spaced Optics Availability," in Free-Space Laser Communication Technologies XIV, G. Stephen Mercherle, Editor, Proceedings of SPIE Vol.4635, pp. 171-178 (2002).
22. Ragazzoni, R., Diolaiti, E., "Rayleigh Link to Overcome Fog Attenuation," in Free-Space Laser Imaging, David G. Voelz, Jennifer C. Ricklin, Editors, Proceedings of SPIE Vol. 4489, pp. 113-117 (2002).
23. Bouzoubaa, M., Nikulin, V. V., Busch, T. E., "Model Reference Control of a Laser Beam Steering System for Laser Communication Applications," in Free-Space Laser Communication Technologies XIII, G. Stephen Mercherle, Editor, Proceedings of SPIE Vol.4272, pp. 93-103 (2001).
24. Terabeam Corporation, "High capacity broadband wireless solutions." [<http://www.terabeam.com>]. May/2003.
25. Canon Corporation, "Home Page." [<http://www.usa.canon.com>]. May/2003.
26. Airfiber, "Carrier class last-mile broadband wireless access equipment." [<http://www.airfiber.com>]. May/2003.
27. Zeroconf, "Zero configuration networking." [<http://www.zeroconf.org>]. May/2003.
28. Apple Computer Corporation, "Rendezvous." [<http://www.apple.com/macosx/jaguar/rendezvous.html>]. May/2003.
29. S&T Manning Affordability, "Integrated Command Environment." [<http://manningaffordability.com>]. May/2003.
30. Davis, Christopher C., Smolyaninov Igor I., Milner, Stuart D., "Flexible Optical Wireless Links and Networks," in IEEE Communications Magazine, Roch H. Glitho, Editor, March 2003, Vol.41 No. 3, pp. 51-57.
31. Ruggiero, Tony, Project SALINAS, Lawrence Livermore National Laboratory, June 2002.

32. Ruggiero, Tony, Project SATRN, Lawrence Livermore
National Laboratory, July 2001.

INITIAL DISTRIBUTION LIST

1. Defense Technical Information Center
Ft. Belvoir, VA
2. Dudley Knox Library
Naval Postgraduate School
Monterey, CA
3. Dr. Dan Boger
Naval Postgraduate School
Monterey, CA
4. Dr. Orin Marvel
Naval Postgraduate School
Monterey, CA